

tM Series DIO User Manual

Warranty

All products manufactured by ICP DAS are under warranty regarding defective materials for a period of one year from the date of delivery to the original purchaser.

Warning

ICP DAS assumes no liability for damages resulting from the use of this product. ICP DAS reserves the right to change this manual at any time without notification. The information furnished by ICP DAS is believed to be accurate and reliable. However, no responsibility is assumed by ICP DAS for its use, or for any infringements of patents or other rights of third parties resulting from its use.

Copyright

Copyright 2012 ICP DAS. All rights reserved.

Trademark

The names used for identification only may be registered trademarks of their respective companies.

Date: 2018/12/28

Table of Contents

1. Introduction	5
1.1 More Information	6
1.2 Terminal Assignment	7
1.3 Specifications	16
1.3.1 I/O Specifications.....	16
1.3.2 System Specifications	20
1.4 Block Diagrams.....	21
1.4.1 Block Diagram for the tM-C8.....	21
1.4.2 Block Diagram for the tM-P8	21
1.4.3 Block Diagram for the tM-PDW8.....	22
1.4.4 Block Diagram for the tM-P4A4	22
1.4.5 Block Diagram for the tM-P4C4.....	23
1.4.6 Block Diagram for the tM-P3POR3	23
1.4.7 Block Diagram for the tM-P3R3.....	24
1.4.8 Block Diagram for the tM-PD3R3.....	24
1.4.9 Block Diagram for the tM-R5	25
1.5 Dimensions.....	26
1.6 Wiring.....	27
1.6.1 tM-C8 wiring.....	27
1.6.2 tM-P8 wiring	27
1.6.3 tM-PDW8 wiring	28
1.6.4 tM-P4A4 wiring	28
1.6.5 tM-P4C4 wiring.....	29
1.6.6 tM-P3POR3 wiring	29
1.6.7 tM-P3R3 wiring.....	30
1.6.8 tM-PD3R3 wiring.....	30
1.6.9 tM-R5 wiring.....	30
1.6.10 Wiring Recommendations.....	31
1.7 Quick Start.....	32
1.8 Default Settings	33
1.9 Configuration Tables.....	34
1.10 DIO Active States.....	37
1.11 Mounting	38
1.11.1 Din-Rail Mounting	38

1.12 Technical Support	40
2. DCON Protocol	41
2.1 %AANNTCCFF	44
2.2 #**	47
2.3 #AA00(Data)	48
2.4 #AA0A(Data)	50
2.5 #AA0B(Data)	52
2.6 #AA1cDD.....	54
2.7 #AAAcDD.....	56
2.8 #AABcDD	58
2.9 #AAN	60
2.10 \$AA2	62
2.11 \$AA4	64
2.12 \$AA5	66
2.13 \$AA6	68
2.14 \$AAC.....	70
2.15 \$AACN.....	72
2.16 \$AAF	74
2.17 \$AALS.....	75
2.18 \$AAM.....	77
2.19 \$AAP	78
2.20 \$AAPN	80
2.21 @AA.....	82
2.22 @AA(Data)	84
2.23 ~AAO(Name)	86
2.24 ~**	88
2.25 ~AA0	89
2.26 ~AA1	91
2.27 ~AA2	93
2.28 ~AA3EVV.....	95
2.29 ~AA4V	97
2.30 ~AA5V	99
2.31 ~AAD	101
2.32 ~AADVV	103
2.33 ~AARD.....	105
2.34 ~AARDVV	107
3. Modbus RTU Protocol	109
3.1 01 (0x01) Read Coils.....	110

3.2 02 (0x02) Read Discrete Inputs	112
3.3 03 (0x03) Read Multiple Registers	113
3.4 04 (0x04) Read Multiple Input Registers.....	114
3.5 05 (0x05) Write Single Coils	115
3.6 15 (0x0F) Write Multiple Coils	117
3.7 70 (0x46) Read/Write Module Settings	119
3.7.1 Sub-function 00 (0x00) Read module name	120
3.7.2 Sub-function 04 (0x04) Set module address.....	121
3.7.3 Sub-function 05 (0x05) Read communication settings	122
3.7.4 Sub-function 06 (0x06) Set communication settings..	123
3.7.5 Sub-function 32 (0x20) Read firmware version	125
3.7.6 Sub-function 33 (0x21) Set digital input counter trigger edge.....	126
3.7.7 Sub-function 34 (0x22) Read digital input counter trigger edge value	127
3.7.8 Sub-function 39 (0x27) Set the power-on value.....	128
3.7.9 Sub-function 40 (0x28) Read the power-on value.....	129
3.7.10 Sub-function 41 (0x29) Set DI/O active states	130
3.7.11 Sub-function 42 (0x2A) Read DI/O active states	132
3.8 Modbus Address Mappings.....	133
4. Troubleshooting.....	136
4.1 Communicating with the module	137
A. Appendix	138
A.1 INIT Mode.....	138
A.2 Dual Watchdog Operation.....	140
A.3 Frame Ground.....	141
A.4 Reset Status	142
A.5 Safe Value and Power-on Value of Digital Output	143
A.6 Latched Digital Input.....	144
A.7 DN Module.....	145
A.7.1 DN-SSR4.....	146
A.7.2 DN-PR4	147
A.7.3 RM-104, RM-108, and RM-116	148
A.7.4 RM-204, RM-208, RM-216	149

1. Introduction

The tM series is a family of network data acquisition and control modules, providing digital input/output and counter functions. The modules can be remotely controlled using a set of commands, which we call the DCON protocol, or the standard Modbus protocol. Communication between the module and the host is via an RS-485/RS-232 bi-directional serial bus standard. Baud Rates are software programmable and transmission speeds of up to 115.2 Kbps can be selected.

The tM series feature a new design for the frame ground and INIT switch as shown in the figure. The frame ground provides enhanced static protection (ESD) abilities and ensures the module is more reliable. The INIT switch allows easier access to INIT mode. Please refer to Sections A.1 and A.3 for more details.



The tM series modules support TTL signal, photo-isolated digital input, relay contact output, solid-state relay output, and open-collector output.

1.1 More Information

- For details of **INIT mode** operation, please refer to Section A.1 INIT Mode.
- For details of **module watchdog** and **host watchdog**, please refer to Section A.2 Dual Watchdog Operation.
- For details of **ESD protection** and **grounding**, please refer to Section A.3 Frame Ground.
- There is a way to check whether the module is reset, please refer to Section A.4 **Reset Status** for details.
- For details of the **safe value** and **power-on value** of the digital output, please refer to Section A.5 Safe Value and Power-on Value of Digital Output.
- The module with digital inputs provides the **latched digital inputs**, please refer to Section A.6 Latched Digital Input for details.
- For details of the **I/O extension modules**, please refer to Section A.7 DN Module.

1.2 Terminal Assignment

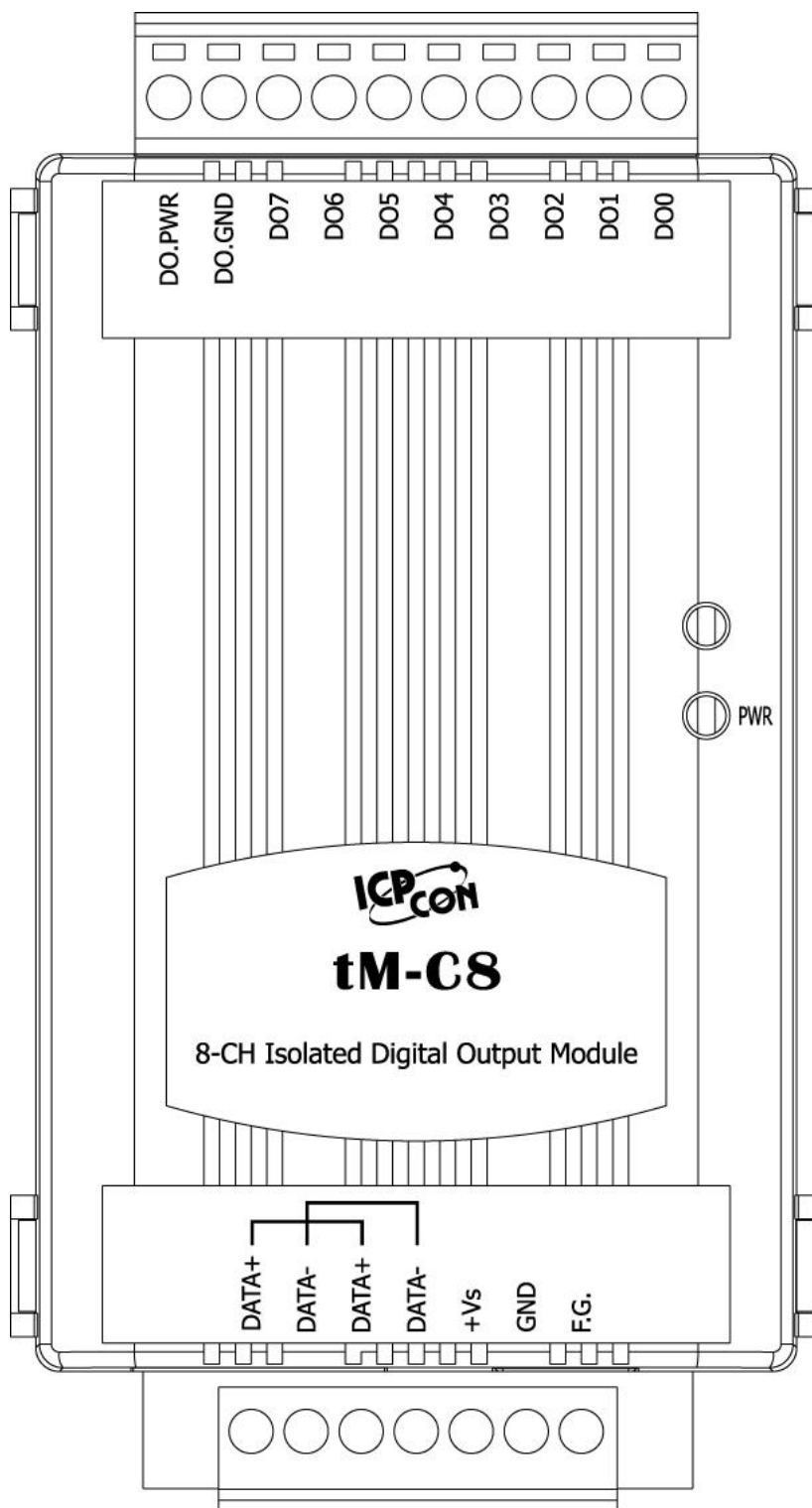

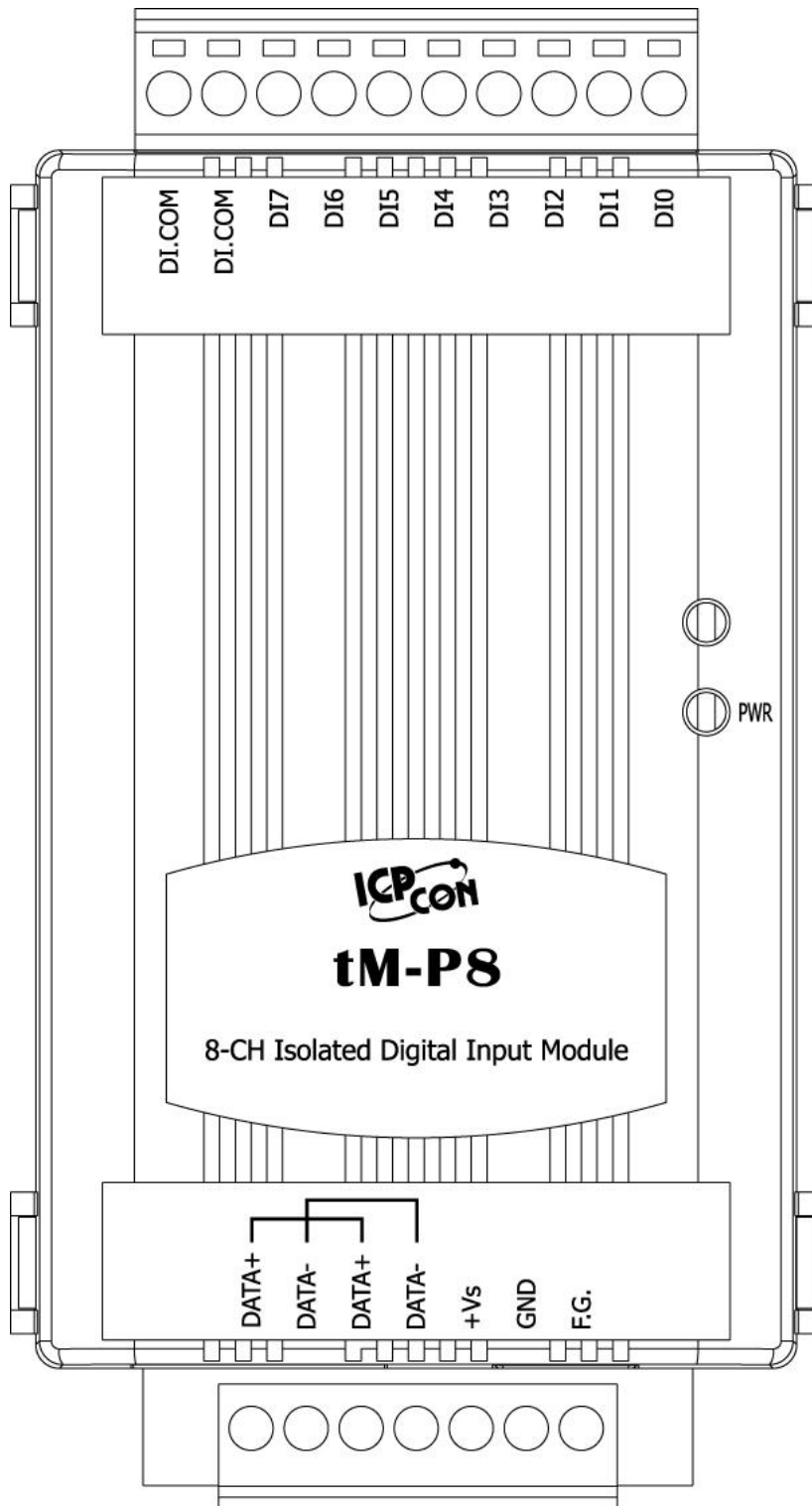

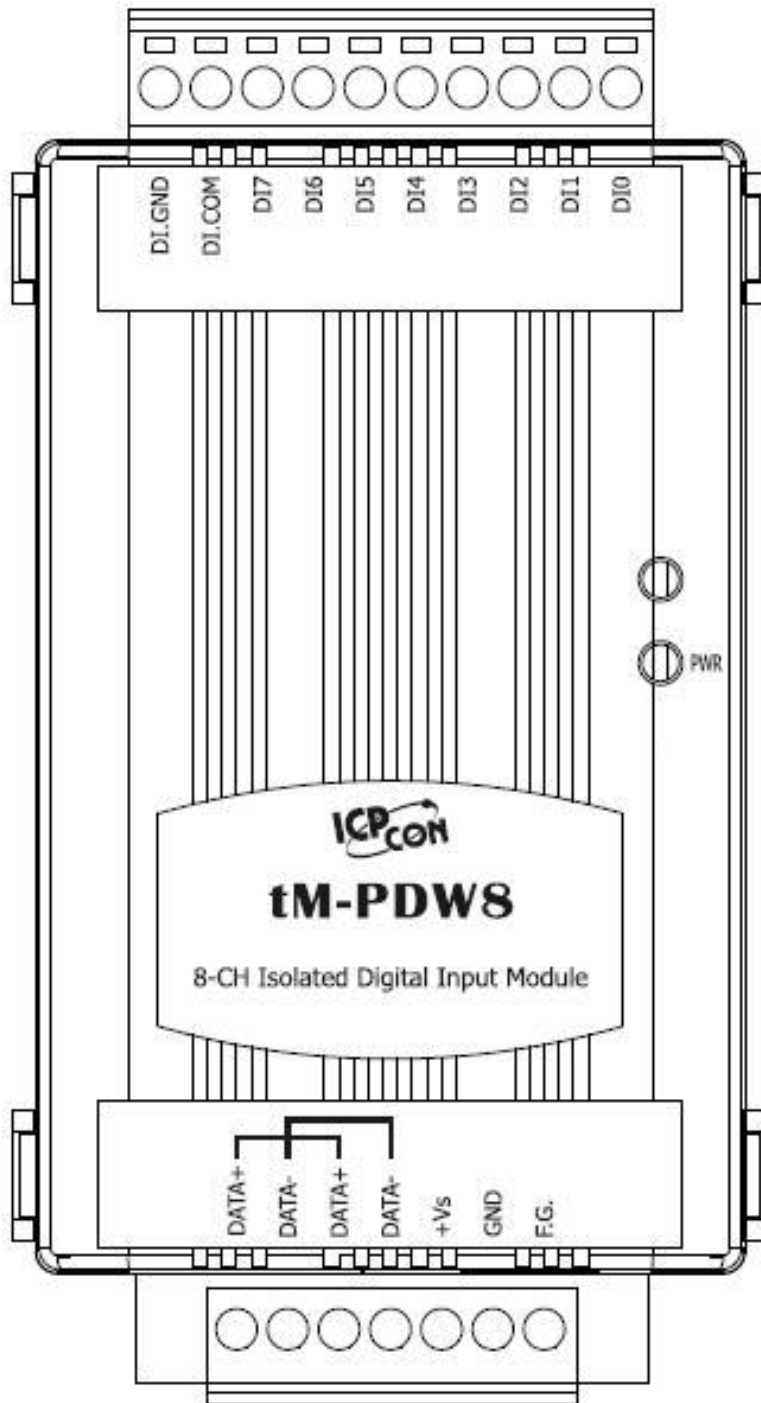

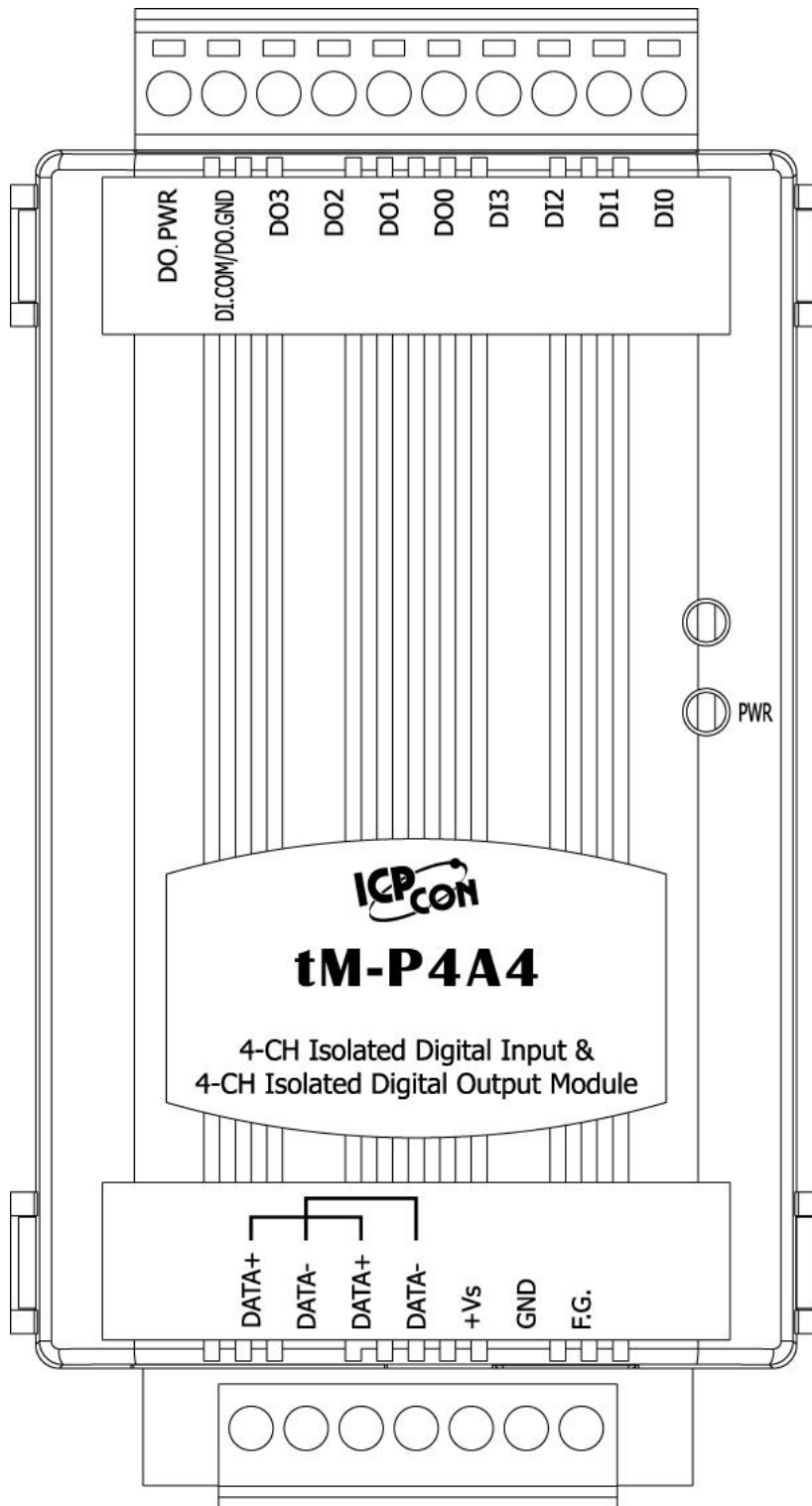

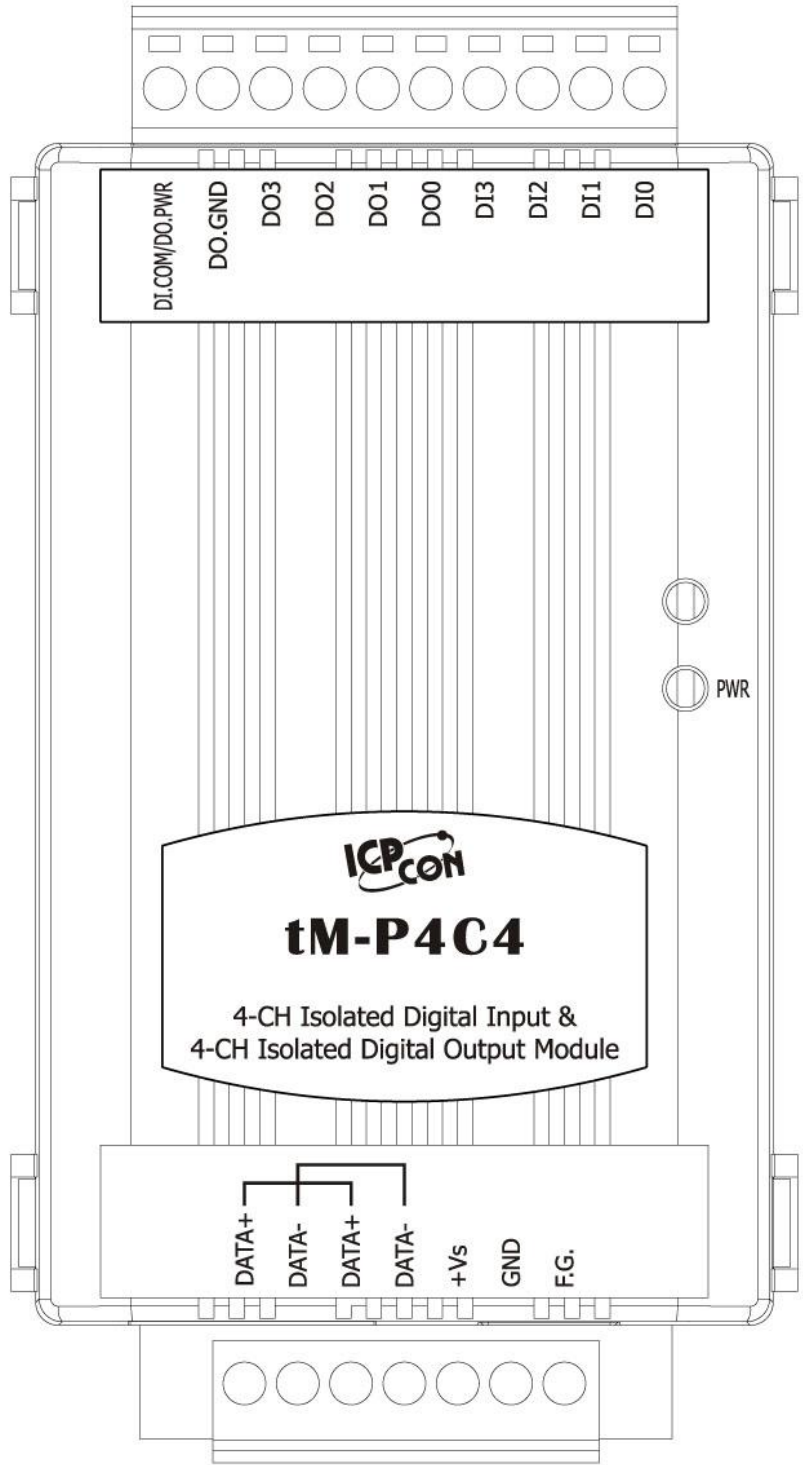

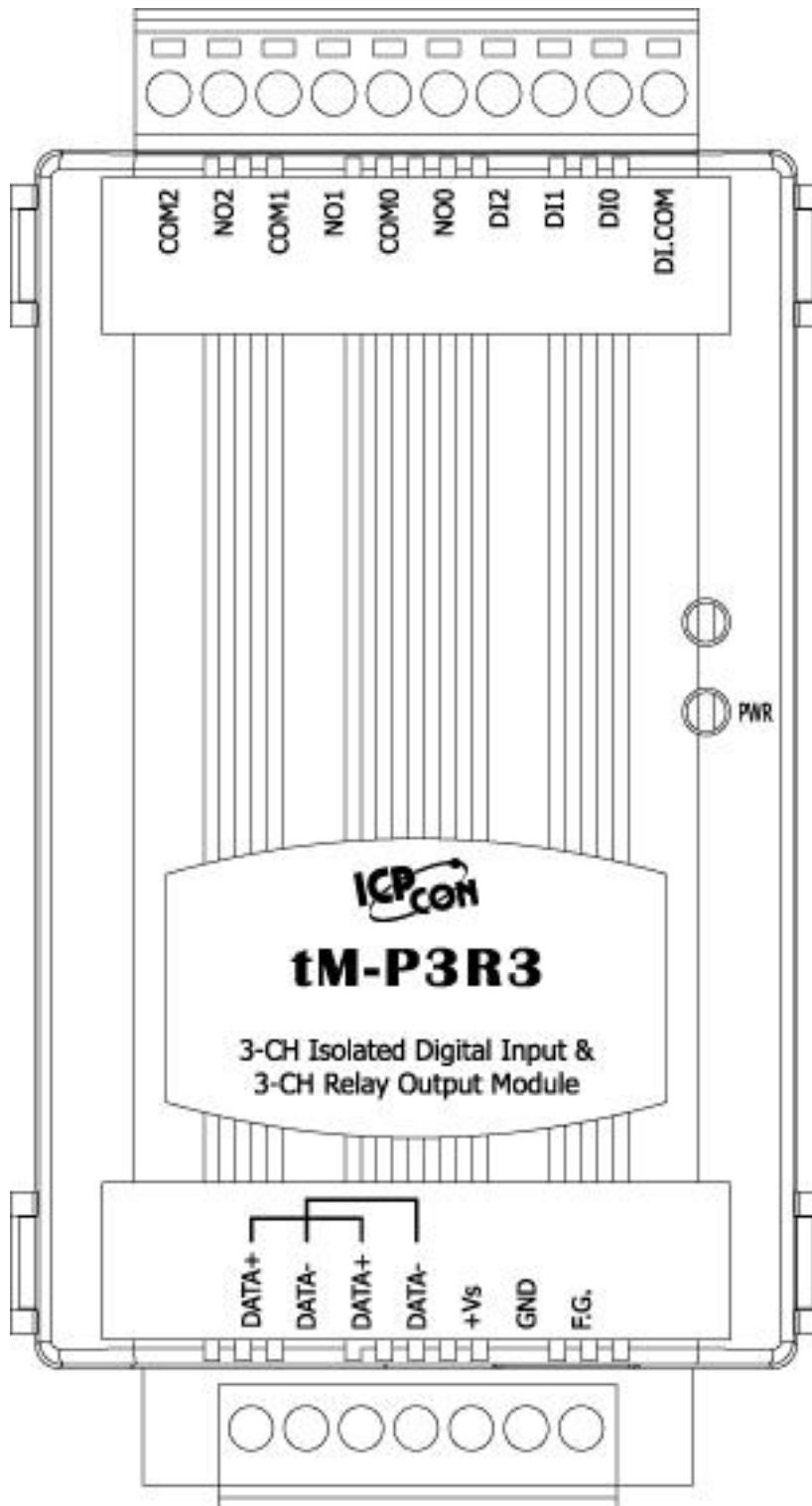

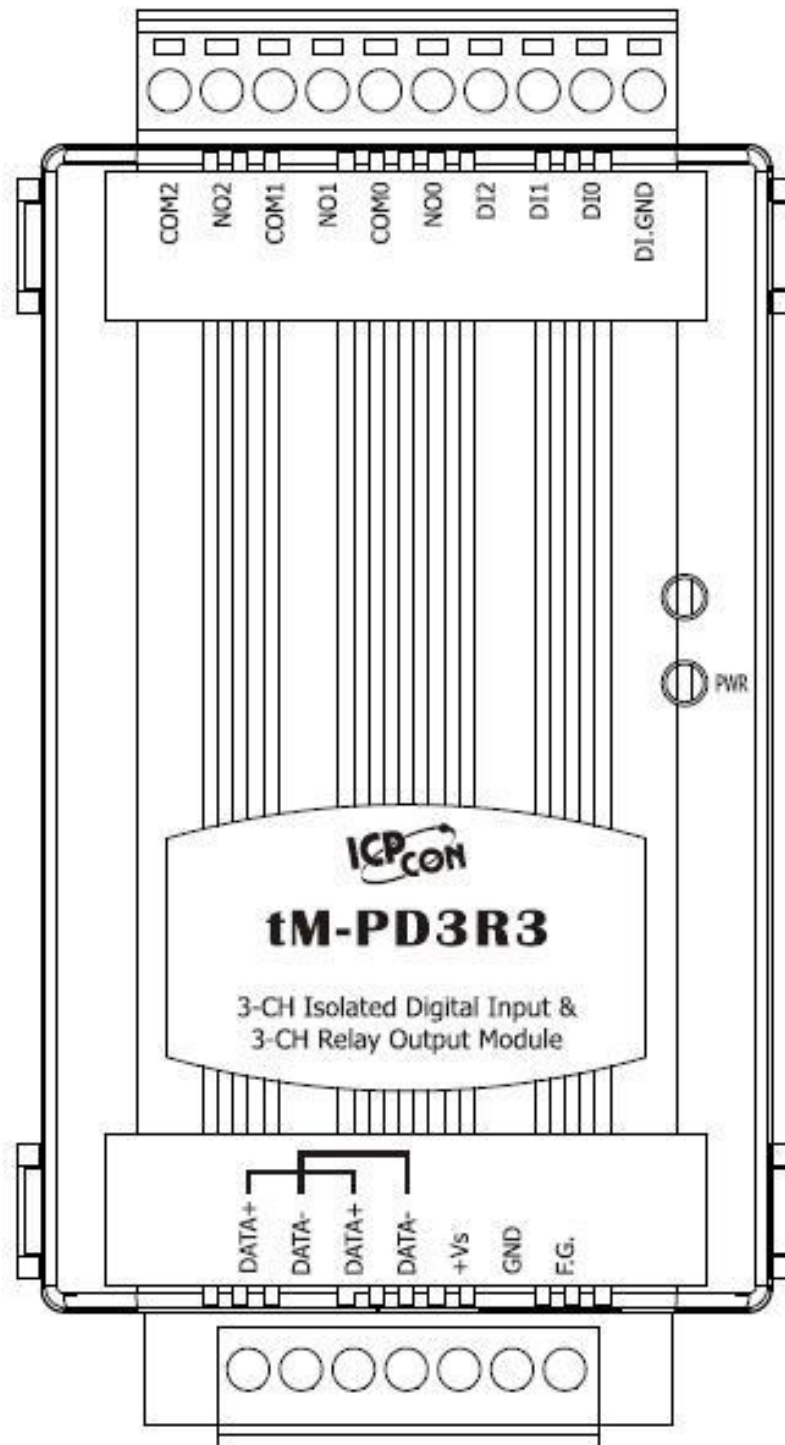

tM-P3POR3

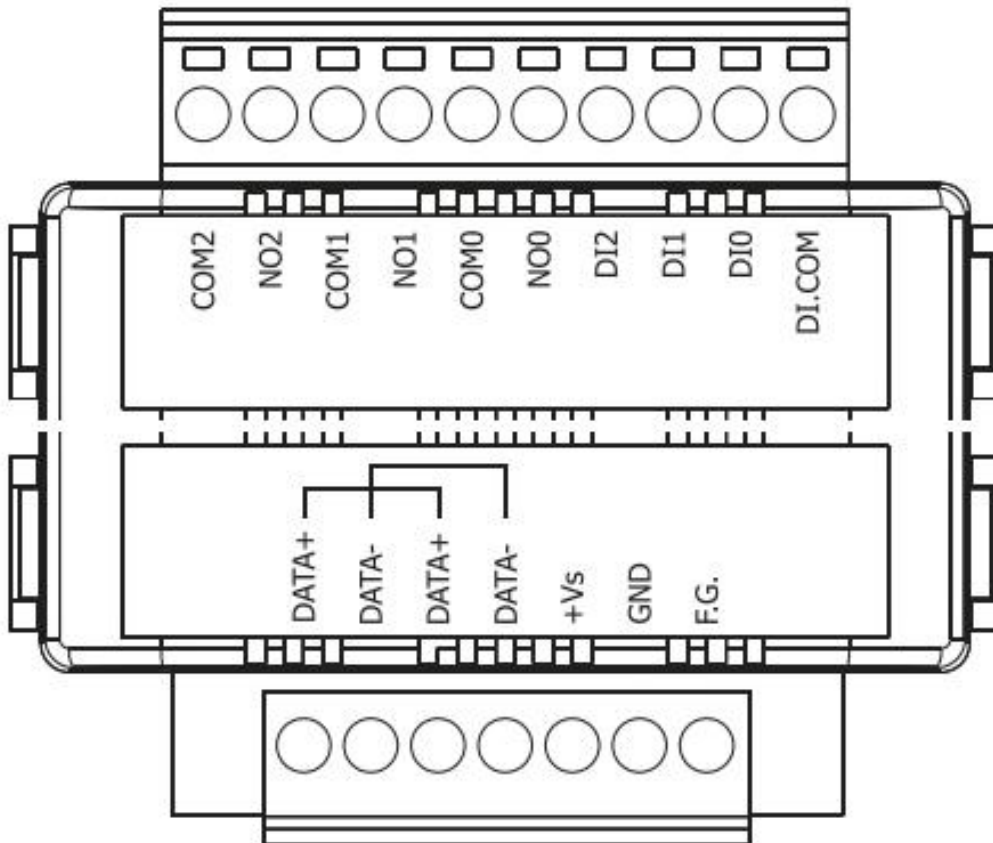

tM-R5

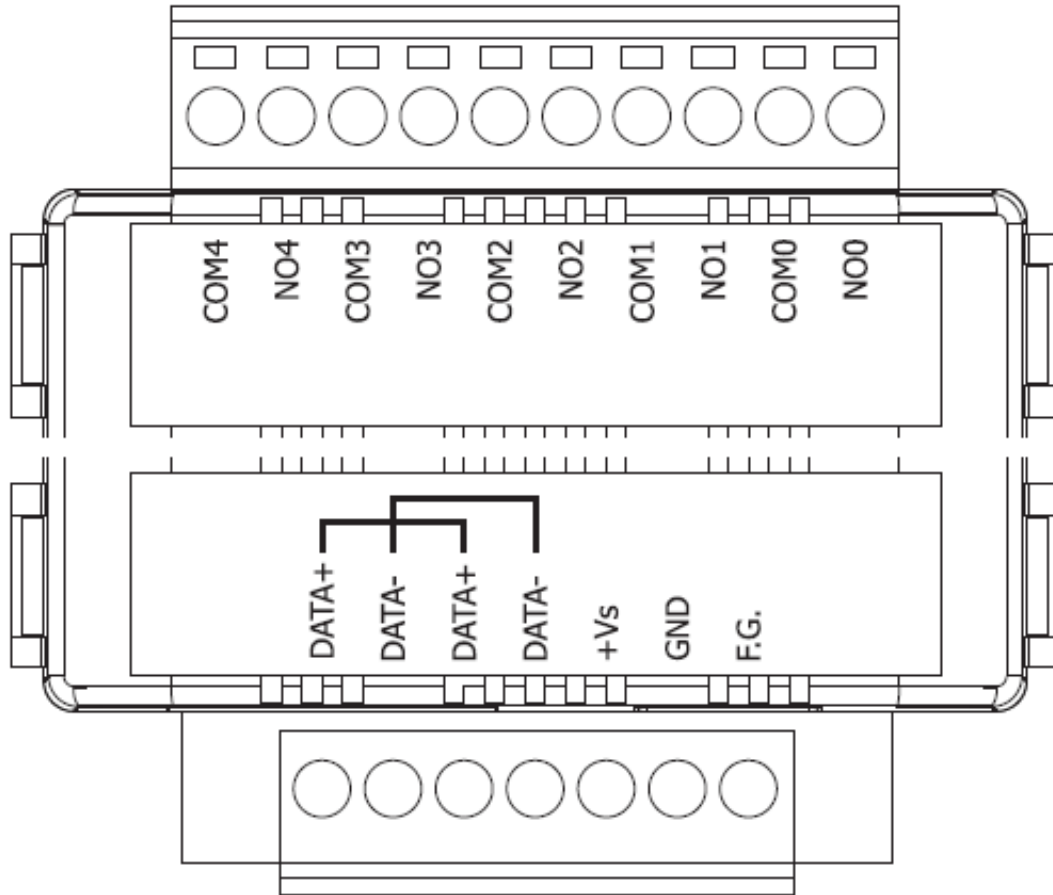

1.3 Specifications

1.3.1 I/O Specifications

Digital Input and Digital Output Module					
Module Name	tM-P4A4	tM-P4C4	tM-C8	tM-P8	
Digital Input/Counter					
Input Channels	4	4	No Digital Input	8	
Type	Wet Contact (Sink)	Wet Contact (Source)		Wet Contact (Sink, Source)	
On Voltage Level	+3.5 ~ +50 VDC	+3.5 ~ +50 VDC		+3.5 ~ +50 VDC	
Off Voltage Level	+1 VDC max.	+1 VDC max.		+1 VDC max.	
Input Impedance	10 K Ω , 0.66 W	10 K Ω , 0.66 W		10 K Ω , 0.66 W	
Counters	Channels	4		4	8
	Max. Count	65535 (16-bit)		65535 (16-bit)	65535 (16-bit)
	Max. Frequency	100 Hz		100 Hz	100 Hz
	Min. Pulse Width	5 ms		5 ms	5 ms
Over-voltage Protection	70 VDC	70 VDC			70 VDC
Digital Output					
Output Channels	4	4	8	No Digital Output	
Type	Isolated Open Emitter (Source)	Isolated Open Collector (Sink)	Isolated Open Collector (Sink)		
Max. Load Current	650 mA/channel	700 mA/channel	700 mA/channel		
Load Voltage	+10 ~ +40 VDC	+3.5 ~ +50 VDC	+3.5 ~ +50 VDC		
Over-voltage Protection	47 VDC	60 VDC	60 VDC		
Overload Protection	Yes	Yes	Yes		
Short Circuit Protection	1.4 A, Yes	1.4 A, Yes	1.4 A, Yes		
Power-on Value	Yes, Programmable	Yes, Programmable	Yes, Programmable		
Safe Value	Yes, Programmable	Yes, Programmable	Yes, Programmable		
Power Requirements					
Reverse Polarity Protection	Yes				
Powered from Terminal Block	Yes, 10 ~ 30 VDC				
Consumption	0.5 W max	0.5 W max	0.8 W max	0.4 W max	

Digital Input Module					
Module Name		tM-P8	tM-PDW8		
Digital Input/Counter					
Input Channels		8	4		
Type		Wet Contact (Sink, Source)	Wet Contact (Source) +Dry Contact(Source)		
Wet Contact	On Voltage Level	+3.5 ~ +50 VDC	+3.5 ~ +50 VDC		
	Off Voltage Level	+1 VDC max.	+1 VDC max.		
Dry Contact	On Voltage Level	-	Close to GND		
	Off Voltage Level	-	Open		
Input Impedance		10 K Ω , 0.5 W	10 K Ω , 0.5 W		
Counters	Channels	8	8		
	Max. Count	65535 (16-bit)	65535 (16-bit)		
	Max. Frequency	100 Hz	100 Hz		
	Min. Pulse Width	5 ms	5 ms		
Over-voltage Protection		\pm 70 VDC	\pm 70 VDC		
Power Requirements					
Reverse Polarity Protection		Yes			
Powered from Terminal Block		Yes, 10 ~ 30 VDC			
Consumption		0.2 W max	0.43 W max		

PhotoMOS Relay Output Module		
Module Name	tM-P3POR3	
PhotoMOS Relay Output		
Output Channels	3	
Type	PhotoMOS Relay	
Operating Load Voltage Range	80 V (AC peak or DC)	
Continuous Load Current	1 A max.	
Peak Load Current	3 A (1 ms, 1 shot)	
Output Off State Leakage Current	1 uA	
Operate Time	5 ms (max.)	
Release Time	0.5 ms (max.)	
Electrical Endurance	Long Life and No Spike	
Power-on Value	Yes, Programmable	
Safe Value	Yes, Programmable	
Digital Input/Counter		
Input Channels	3	
Type	Wet Contact (Sink, Source)	
On Voltage Level	+3.5 ~ +50 VDC	
Off Voltage Level	+1 VDC max.	
Input Impedance	10 K Ω , 0.66 W	
Counters	Channels	3
	Max. Count	65535 (16-bit)
	Max. Input Frequency	100 Hz
	Min. Pulse Width	5 ms
Over-voltage Protection	70 VDC	
Power Requirements		
Reverse Polarity Protection	Yes	
Powered from Terminal Block	Yes, 10 ~ 30 VDC	
Consumption	0.4 W max	

Relay Output Module				
Module Name		tM-P3R3	tM-PD3R3	tM-R5
Relay Output				
Output Channels		3	3	5
Type		Power Relay, Form A (SPST N.O.)	Power Relay, Form A (SPST N.O.)	Power Relay, Form A (SPST N.O.)
Operating Voltage Range		250 VAC or 30 VDC	250 VAC or 30 VDC	250 VAC or 30 VDC
Max. Load Current		5 A	5 A	5 A
Operate Time		6 ms	6 ms	6 ms
Release Time		3 ms	3 ms	3 ms
Electrical Life (Resistive load)	VDE	5 A @250 VAC 30,000 ops (10 ops/minute) at 75°C	5 A @250 VAC 30,000 ops (10 ops/minute) at 75°C	5 A @250 VAC 30,000 ops (10 ops/minute) at 75°C
		5 A @30 VDC 70,000 ops (10 ops/minute) at 75°C	5 A @30 VDC 70,000 ops (10 ops/minute) at 75°C	5 A @30 VDC 70,000 ops (10 ops/minute) at 75°C
	UL	5 A @250 VAC/30 VDC 6,000 ops	5 A @250 VAC/30 VDC 6,000 ops	5 A @250 VAC/30 VDC 6,000 ops
		3 A @250 VAC/30 VDC 100,000 ops	3 A @250 VAC/30 VDC 100,000 ops	3 A @250 VAC/30 VDC 100,000 ops
Mechanical Life		20,000,000 ops at no load (300 ops/minute)	20,000,000 ops at no load (300 ops/minute)	20,000,000 ops at no load (300 ops/minute)
Power-on Value		Yes, Programmable	Yes, Programmable	Yes, Programmable
Safe Value		Yes, Programmable	Yes, Programmable	Yes, Programmable
Digital Input/Counter				
Input Channels		3	3	No Digital Input
Type		Wet Contact (Sink, Source)	Dry Contact (Source)	
Wet Contact	On Voltage Level	+3.5 ~ +50 VDC		
	Off Voltage Level	+1 VDC max.		
Dry Contact	On Voltage Level		Close to GND	
	Off Voltage Level		Open	
Counters	Max. Count	65535 (16-bit)	65535 (16-bit)	
	Max. Input Frequency	100 Hz	100 Hz	
	Min. Pulse Width	5 ms	5 ms	
Input Impedance		10 KΩ, 0.5 W	NA	
Over-voltage Protection		70 VDC	NA	
Power Requirements				
Reverse Polarity Protection		Yes		
Powered from Terminal Block		Yes, 10 ~ 30 VDC		
Consumption		0.8 W max	0.9 W max	1.0 W max

1.3.2 System Specifications

Communication	
Interface	RS-485
Format	(N, 8, 1), (N, 8, 2), (O, 8, 1), (E, 8, 1)
Baud Rate	1200 ~ 115200 bps
Protocol	DCON, Modbus RTU, Modbus ASCII
Dual Watchdog	Yes, Module (2.3 seconds), Communication (Programmable)
LED Indicators	
Power	1 LED as Power Indicator
Isolation	
Intra-module Isolation, Field-to-logic	3750 VDC
EMS Protection	
ESD (IEC 61000-4-2)	±4 kV contact for each terminal
	±8 kV air for random point
EFT (IEC 61000-4-4)	±4 kV for power
Mechanical	
Dimensions (W x L x H)	52 mm x 27 mm x 98 mm
Installation	DIN-Rail Mounting
Environment	
Operating Temperature	-25 ~ +75 °C
Storage Temperature	-30 ~ +75 °C
Humidity	10 ~ 95% RH, non-condensing

1.4 Block Diagrams

1.4.1 Block Diagram for the tM-C8

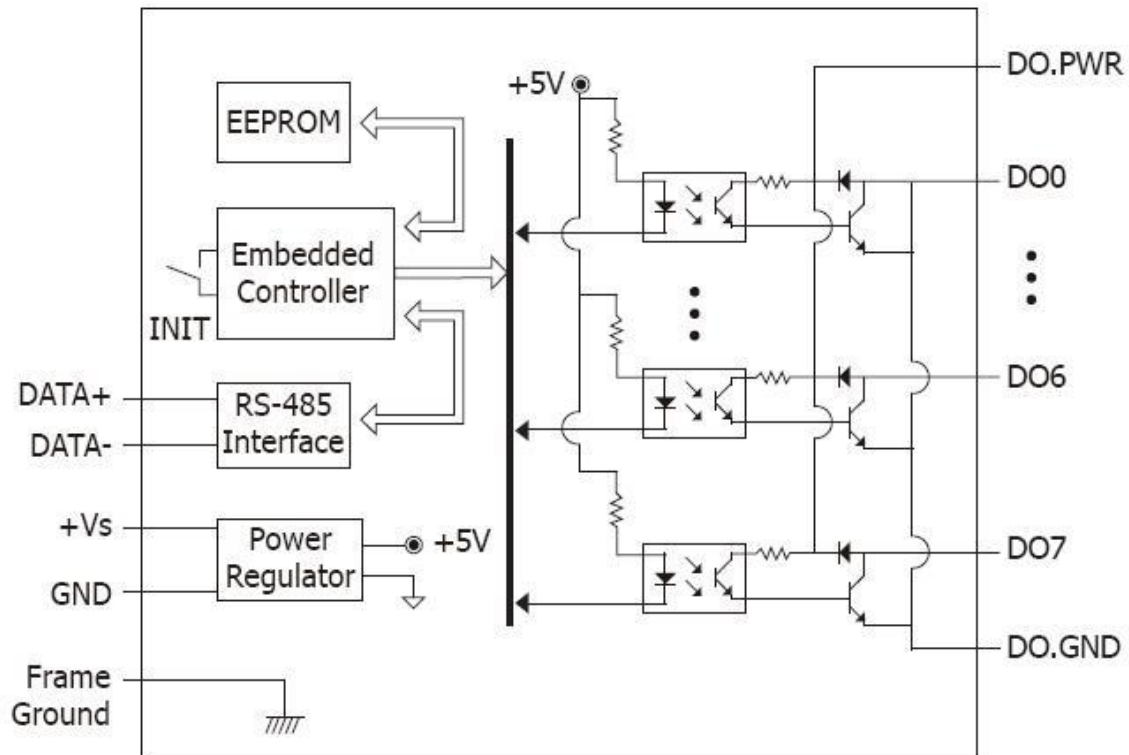

1.4.2 Block Diagram for the tM-P8

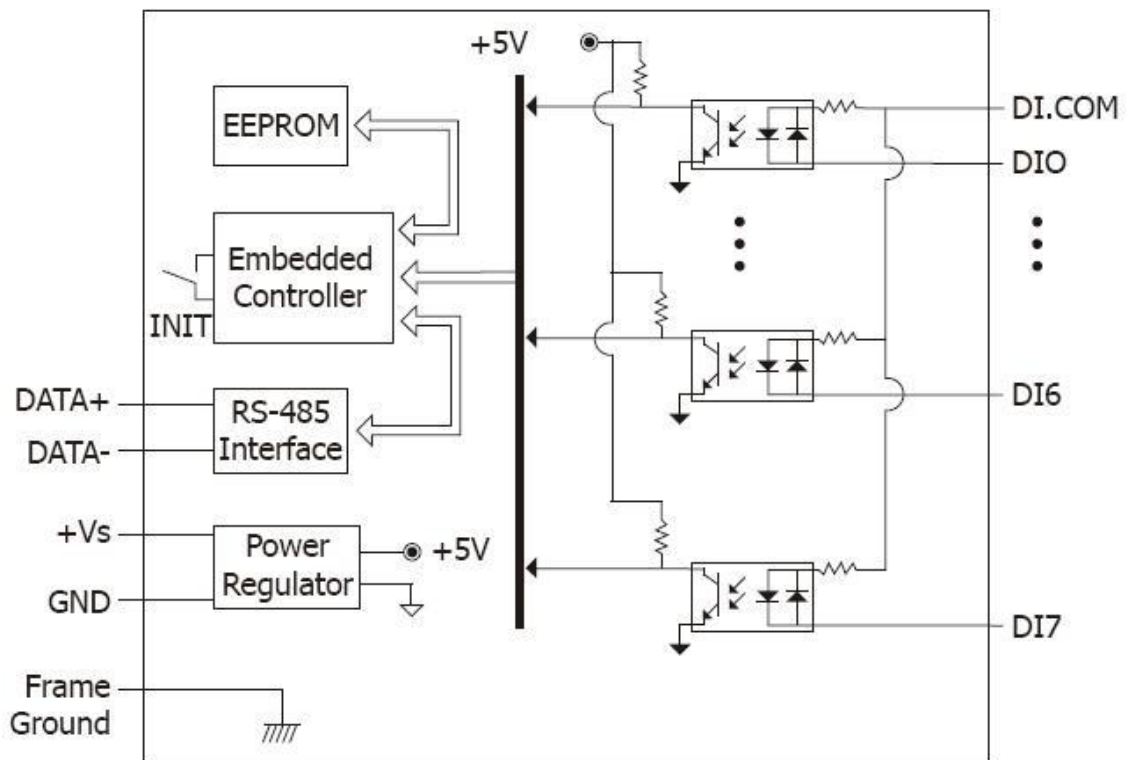

1.4.3 Block Diagram for the tM-PDW8

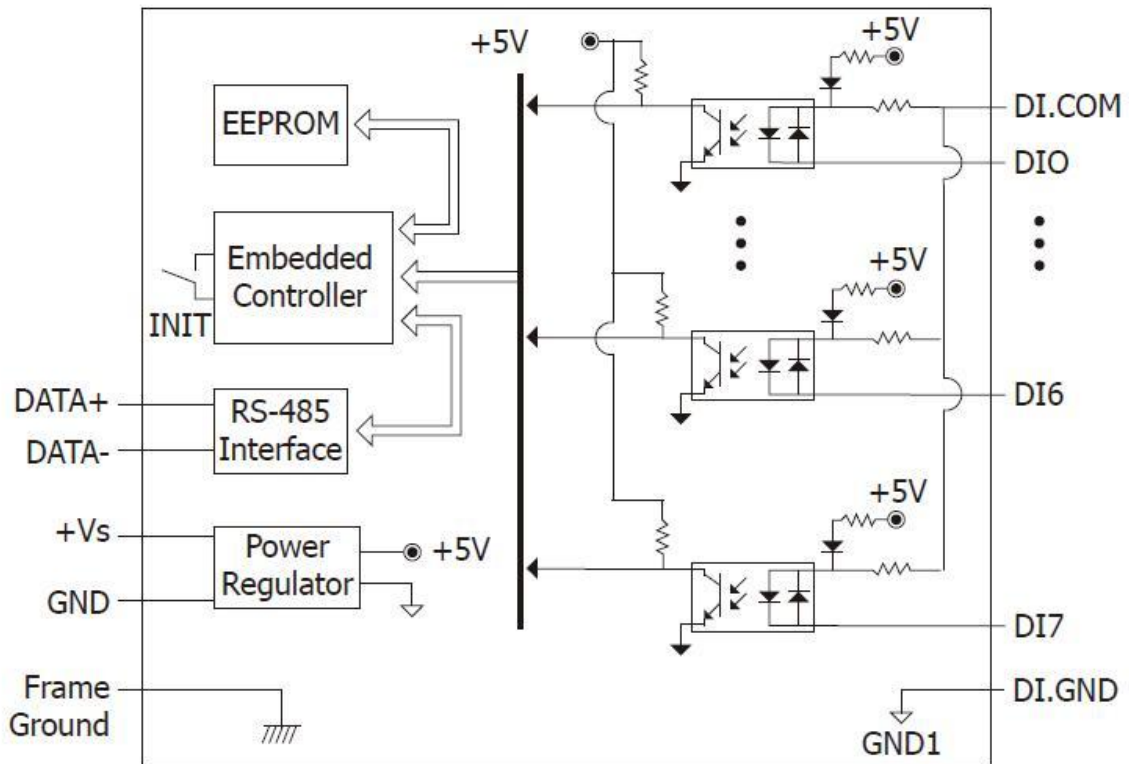

1.4.4 Block Diagram for the tM-P4A4

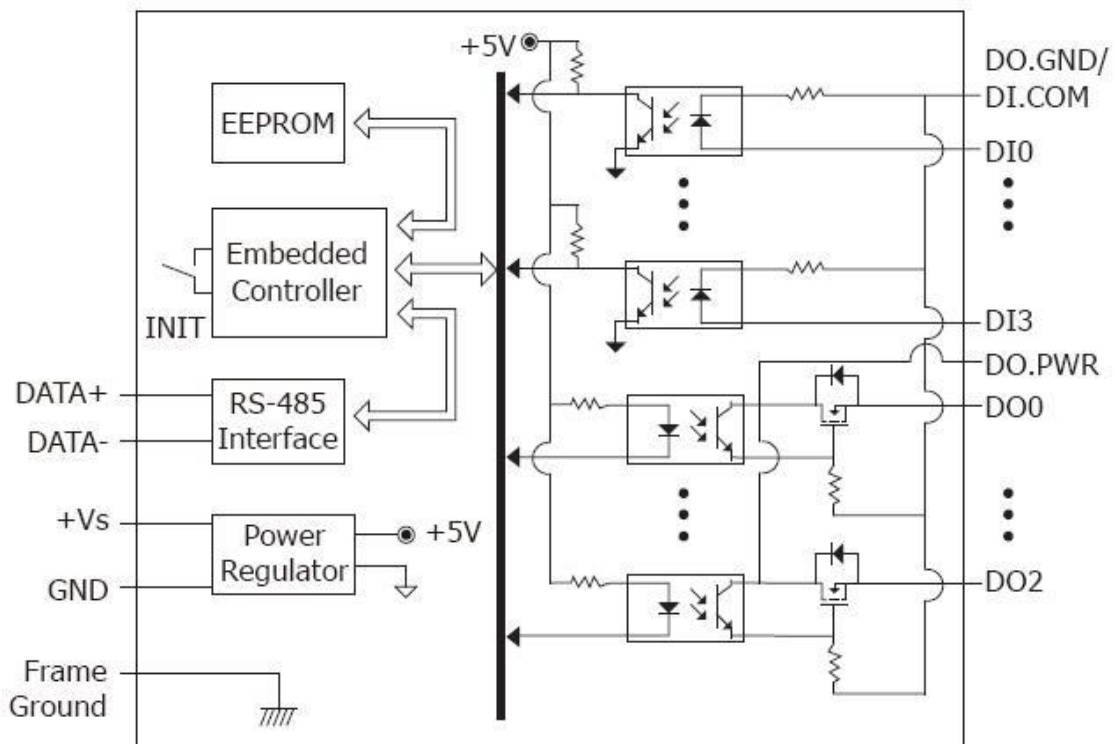

1.4.5 Block Diagram for the tM-P4C4

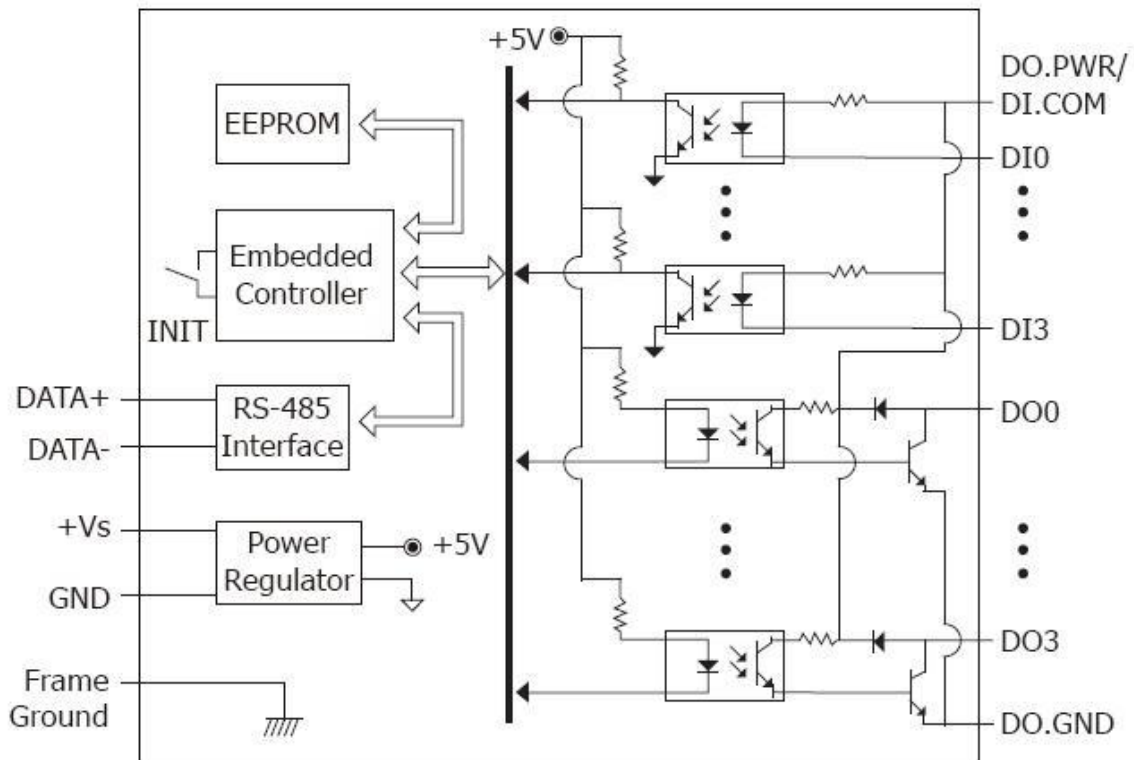

1.4.6 Block Diagram for the tM-P3POR3

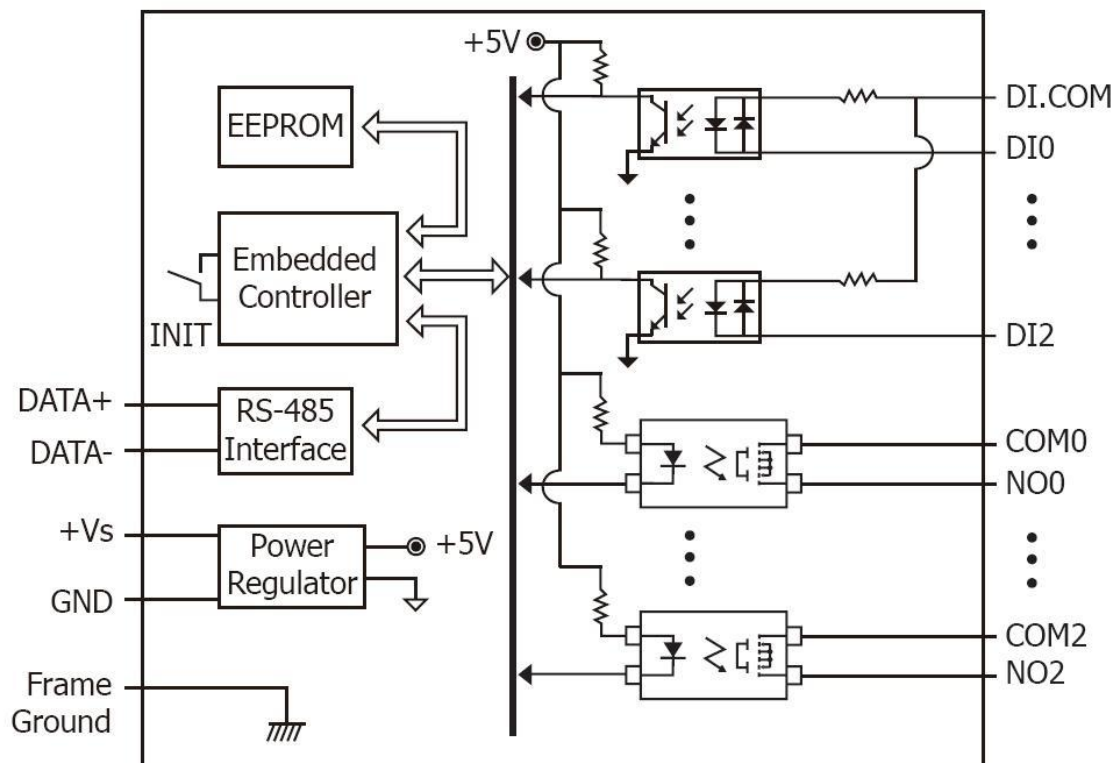

1.4.7 Block Diagram for the tM-P3R3

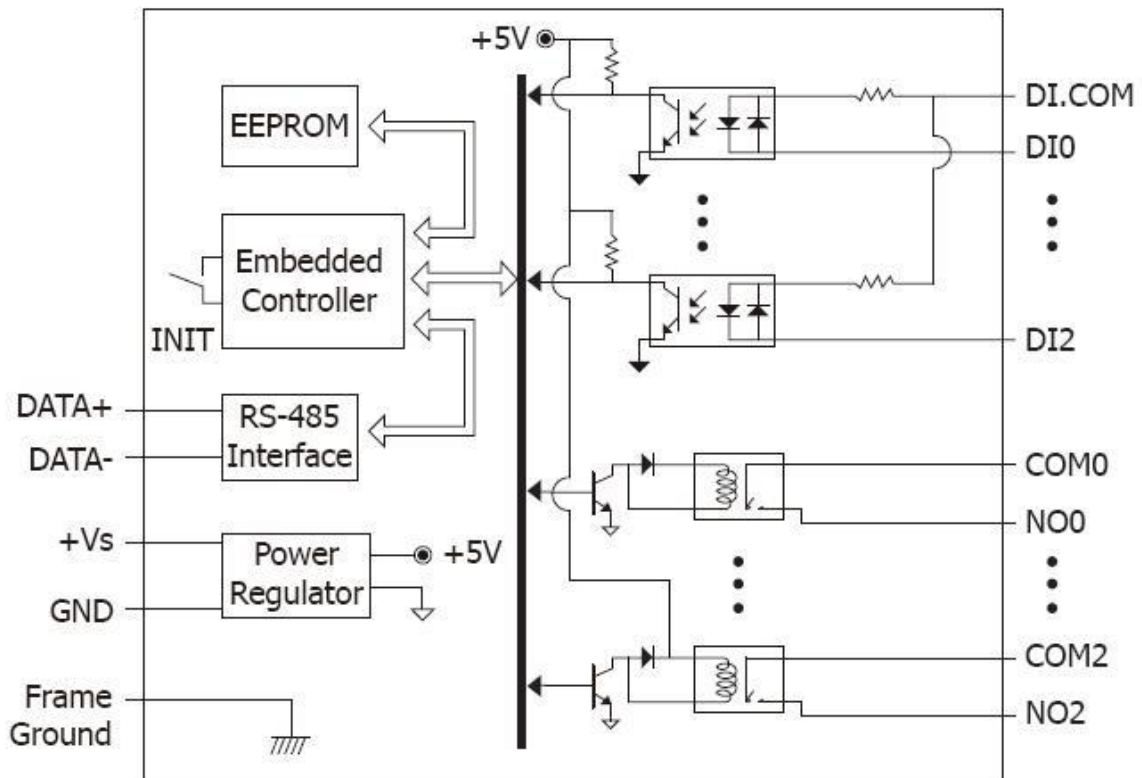

1.4.8 Block Diagram for the tM-PD3R3

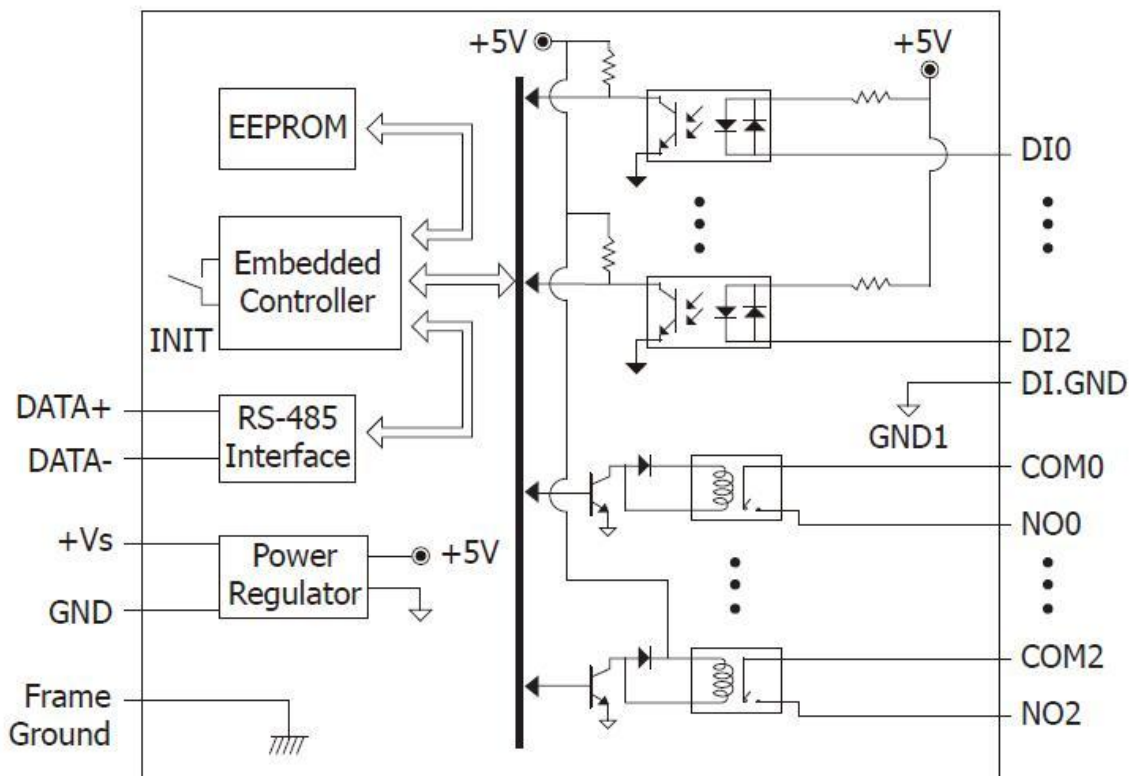

1.4.9 Block Diagram for the tM-R5

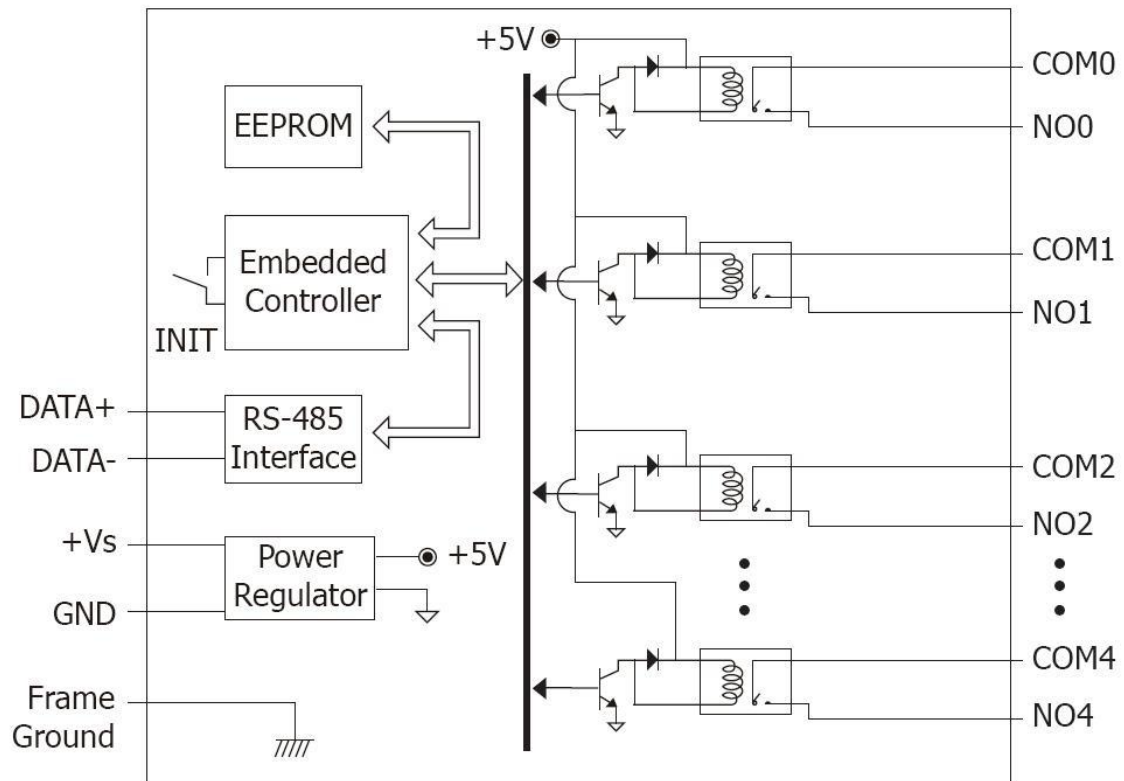

1.5 Dimensions

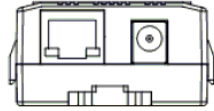

Top View

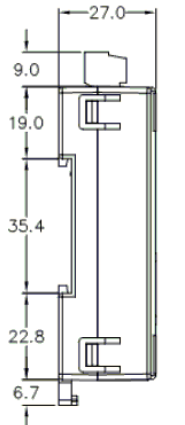

Left Side View

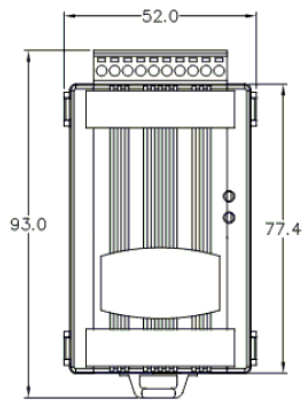

Front View

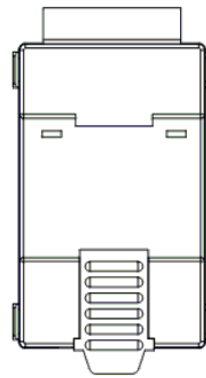

Back View

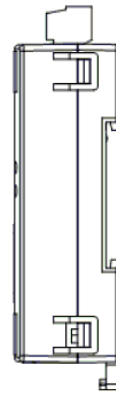

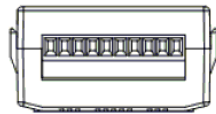

Right Side View



Bottom View

1.6 Wiring

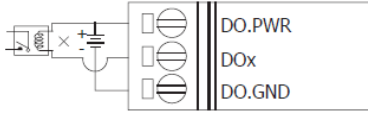
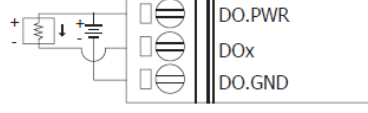
1.6.1 tM-C8 wiring

Output Type	ON State Readback as 1	OFF State Readback as 0
Drive Relay	Relay ON 	Relay OFF 
	Resistance Load 	Resistance Load 

1.6.2 tM-P8 wiring

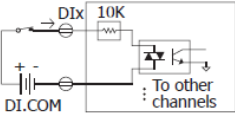
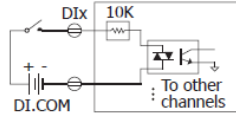
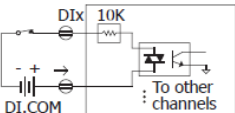
Digital Input/Counter	ON State Readback as 1	OFF State Readback as 0
Sink	+3.5 ~ +50 V _{DC} 	OPEN or <1 V _{DC} 
	Source	+3.5 ~ +50 V _{DC} 

1.6.3 tM-PDW8 wiring

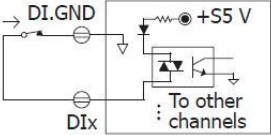
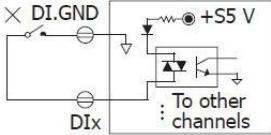
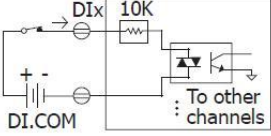
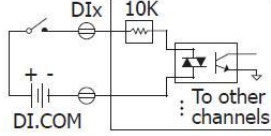
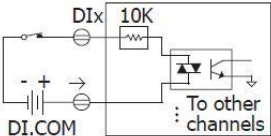
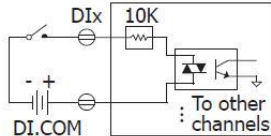
Model	tM-PDW8	
Input Type	ON State Readback as 1	OFF State Readback as 0
Dry Contact	Close to GND	Open
		
Model	tM-P8 / tM-PDW8	
Input Type	ON State Readback as 1	OFF State Readback as 0
Wet Contact (Sink)	+3.5 ~ +50 Vdc	OPEN or <1 Vdc
		
Wet Contact (Source)	+3.5 ~ +50 Vdc	OPEN or <1 Vdc
		

1.6.4 tM-P4A4 wiring

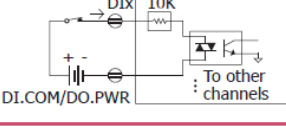
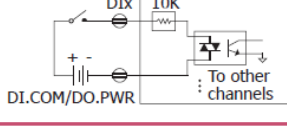
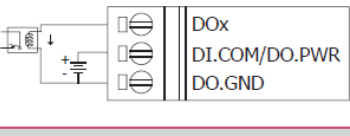
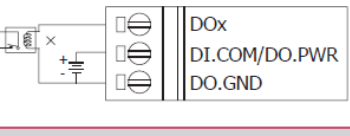
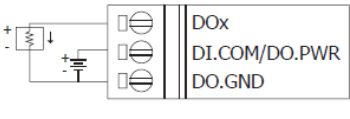
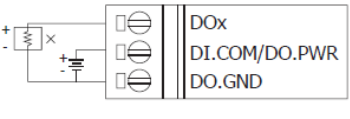
Digital Input/Counter	ON State Readback as 1	OFF State Readback as 0
Sink	+3.5 ~ +50 Vdc	OPEN or <1 Vdc
		
Output Type	ON State Readback as 1	OFF State Readback as 0
Drive Relay	Relay ON	Relay OFF
		
Resistance Load		
		

1.6.5 tM-P4C4 wiring

Digital Input/Counter	ON State Readback as 1 +3.5 ~ +50 Vdc	OFF State Readback as 0 OPEN or <1 Vdc
Source		
Output Type	ON State Readback as 1 Relay ON	OFF State Readback as 0 Relay OFF
Drive Relay		
Resistance Load		

1.6.6 tM-P3POR3 wiring

Digital Input/Counter	ON State Readback as 1 +3.5 ~ +50 Vdc	OFF State Readback as 0 OPEN or <1.0 Vdc
Sink		
Source		
PhotoMOS Relay	ON State Readback as 1	OFF State Readback as 0
Relay Output		

1.6.7 tM-P3R3 wiring

Digital Input/Counter	ON State Readback as 1 +3.5 ~ +50 Vdc	OFF State Readback as 0 OPEN or <1 Vdc
Sink		
Source		
Power Relay	ON State Readback as 1	OFF State Readback as 0
Relay Output		

1.6.8 tM-PD3R3 wiring

Model	tM-PD3R3	
Input Type	ON State Readback as 1	OFF State Readback as 0
Dry Contact	Close to GND 	Open
Power Relay	ON State Readback as 1	OFF State Readback as 0
Relay Output		

1.6.9 tM-R5 wiring

Power Relay	ON State Readback as 1	OFF State Readback as 0
Relay Output		

1.6.10 Wiring Recommendations

- Use 26-12 AWG wire for signal connections.
- Strip the wire to a length of 7 ± 0.5 mm.
- Use a crimp terminal for wiring.
- Avoid high-voltage cables and power equipment as much as possible.
- For RS-485 communication, use insulated and twisted pair 24 AWG wire, e.g. Belden 9841.

1.7 Quick Start

Please refer to the Quick Start Guide for tM series DIO.

1.8 Default Settings

Default settings for the tM DIO modules are as follows:

- Protocol: Modbus RTU
- Module Address: 01
- DIO Type: Type 40
- Baud Rate: 9600 bps

1.9 Configuration Tables

Baud Rate Setting (CC)

7	6	5	4	3	2	1	0
Data		Baud					

Key	Description
Baud	Baud Rate 03: 1200 04: 2400 05: 4800 06: 9600 07: 19200 08: 38400 09: 57600 0A: 115200
Data	Data Format 0: eight data bits, no parity, and one stop bit 1: eight data bits, no parity, and two stop bit 2: eight data bits, even parity, and one stop bit 3: eight data bits, odd parity, and one stop bit

Type Setting (TT)

For tM modules, the type code is fixed to 40.

Data Format Setting (FF)

7	6	5	4	3	2	1	0
CU	CS	reserved			CD		

Key	Description
CD	Code tM-P4C4: 1 (read only) For other modules, the code value can be changed by %AANNTTCCFF command and the default code value is 0.
CS	Checksum setting 0: Disabled 1: Enabled
CU	Counter update 0: The counter is updated when there is a falling edge in the input signal. 1: The counter is updated when there is a rising edge in the input signal.

Note: The reserved bits should be zero.

Digital Input/Output Data Format Table

The data format of the response of the \$AA4, \$AA6 and \$AALS commands is: **(the First Data)(the Second Data)00**.

The data format of the response of the @AA command is: **(the First Data)(the Second Data)**.

Note: both the First Data and the Second Data are in two hexadecimal digits format.

Module	The First Data		The Second Data	
tM-P8	DI1 ~ DI8	00 ~ FF		00
tM-PDW8	DI1 ~ DI8	00 ~ FF		00
tM-P4C4	DO1 ~ DO4	00 ~ 0F	DI1 ~ DI4	00 ~ 0F
tM-P4A4	DO1 ~ DO4	00 ~ 0F	DI1 ~ DI4	00 ~ 0F
tM-P3POR3	DO1 ~ DO3	00 ~ 07	DI1 ~ DI3	00 ~ 07
tM-P3R3	DO1 ~ DO3	00 ~ 07	DI1 ~ DI3	00 ~ 07
tM-PD3R3	DO1 ~ DO3	00 ~ 07	DI1 ~ DI3	00 ~ 07
tM-C8	DO1 ~ DO8	00 ~ FF		00
tM-R5	DO1 ~ DO5	00 ~ 1F		00

1.10 DIO Active States

The DIO read value of the tM modules are as follows:

	DIO	Inactive	Active
tM-P8	8DI	OFF	ON
tM-PDW8	8DI	OFF	ON
tM-P4C4	4DO	OFF	ON
	4DI	OFF	ON
tM-P4A4	4DO	OFF	ON
	4DI	OFF	ON
tM-P3POR3	3DO	OFF	ON
	3DI	OFF	ON
tM-P3R3	3DO	OFF	ON
	3DI	OFF	ON
tM-PD3R3	3DO	OFF	ON
	3DI	OFF	ON
tM-C8	8DO	OFF	ON
tM-R5	5DO	OFF	ON
ON means the DIO read value is 1. OFF means the DIO read value is 0.			

1.11 Mounting

1.11.1 Din-Rail Mounting

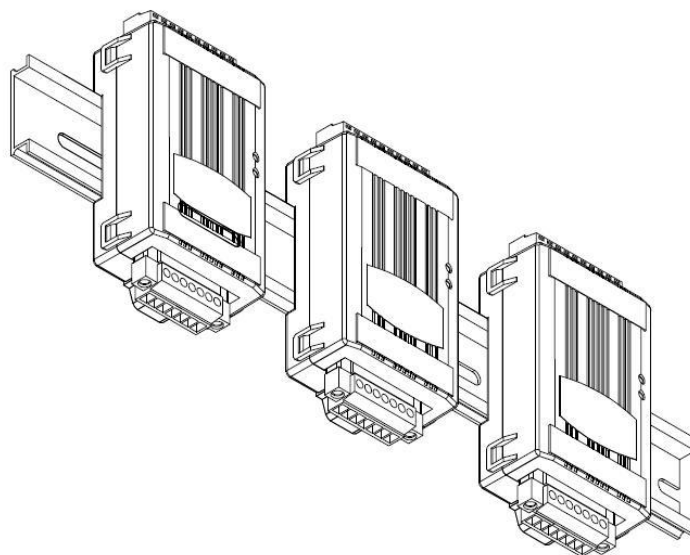

There are three new DIN rail models available. Each is made of stainless steel, which is stronger than those made of aluminum. There is a screw at one end and a ring terminal is included so that it can be easily connected to the earth ground. The three new DIN rail models are as follows.

Part number	Max. number of modules	Dimensions
DRS-360	6	360mm x 35mm

to earth ground

Part number	Max. number of modules	Dimensions
DRS-240	4	240mm x 35mm

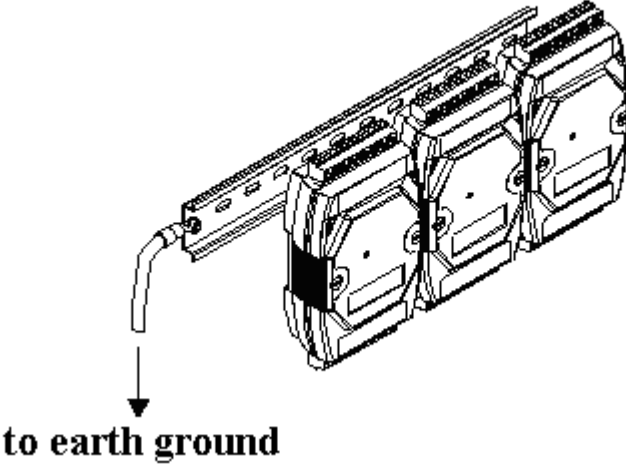

The diagram shows four DRS-240 modules mounted on a DIN rail. A wire is connected to the rail and labeled "to earth ground" with a downward-pointing arrow.

Part number	Max. number of modules	Dimensions
DRS-125	2	125mm x 35mm

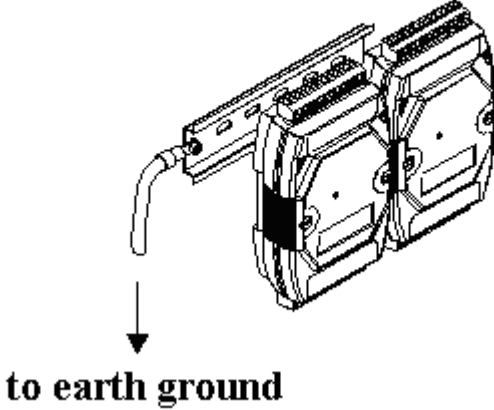

The diagram shows two DRS-125 modules mounted on a DIN rail. A wire is connected to the rail and labeled "to earth ground" with a downward-pointing arrow.

Note: It is recommended that a 16 – 14 AWG wire is used to connect the DIN rail to the earth ground.

1.12 Technical Support

Should you encounter any problems while using the tM module, and are unable to find the help you need in this manual or on our website, please contact ICP DAS Product Support.

Email: service@icpdas.com

Website:

http://www.icpdas.com.tw/contact_us/contact_us.html

When requesting technical support, be prepared to provide the following information about your system:

1. Module name and serial number: The serial number can be found printed on the barcode label attached to the cover of the module.
2. Firmware version: See Sections 2.16 and 3.7.5 for information regarding the command used to identify the firmware version.
3. Host configuration (type and operating system)
4. If the problem is reproducible, please give full details describing the procedure used to reproduce the problem.
5. Any specific error messages displayed. If a dialog box with an error message is displayed, please include the full text of the dialog box, including the text in the title bar.
6. If the problem involves other programs or hardware devices, please describe the details of the problem in full.
7. Any comments and suggestions related to the problem are welcome.

ICP DAS will reply to your request by email within three business days.

2. DCON Protocol

All communication with tM modules consists of commands generated by the host and responses transmitted by the tM modules. Each module has a unique ID number that is used for addressing purposes and is stored in non-volatile memory. The ID is 01 by default and can be changed using a user command. All commands to the modules contain the ID address, meaning that only the addressed module will respond. The only exception to this is commands #** (Section 2.2) and ~** (Section 2.24), which are sent to all modules, but in both of these cases, the modules do not reply to the command.

Command Format:

Leading Character	Module Address	Command	[CHKSUM]	CR
--------------------------	-----------------------	----------------	-----------------	-----------

Response Format:

Leading Character	Module Address	Data	[CHKSUM]	CR
--------------------------	-----------------------	-------------	-----------------	-----------

- CHKSUM** A 2-character checksum which is present when the checksum setting is enabled. See Sections 1.9 (Data Format Setting) and 2.1 for details.
- CR** End of command character, carriage return (0x0D)

Checksum Calculation:

1. Calculate the ASCII code sum of all the characters in the command/response string except for the carriage return character (CR).
2. The checksum is equal to the sum masked by 0FFh.

Example:

Command string: \$012(CR)

1. Sum of the string = "\$"+"0"+"1"+"2" =
 $24h+30h+31h+32h = B7h$
2. Therefore the checksum is B7h, and so
CHKSUM = "B7"
3. The command string with the checksum = \$012B7(CR)

Response string: !01200600(CR)

1. Sum of the string =
"!"+"0"+"1"+"2"+"0"+"0"+"6"+"0"+"0" =
 $21h+30h+31h+32h+30h+30h+36h+30h+30h = 1AAh$
2. Therefore the checksum is AAh, and so
CHKSUM = "AA"
3. The response string with the checksum
= !01200600AA(CR)

Note:

All characters should be in upper case.

General Command Sets			
Command	Response	Description	Section
%AANNTTCCFF	!AA	Sets the Module Configuration	2.1
***	No Response	Synchronized Sampling	2.2
#AA00(Data)	>	Sets the Digital Output	2.3
#AA0A(Data)	>	Sets the Digital Output	2.4
#AA0B(Data)	>	Sets the Digital Output	2.5
#AA1cDD	>	Sets the Digital Output	2.6
#AAAcDD	>	Sets the Digital Output	2.7
#AABcDD	>	Sets the Digital Output.	2.8
#AAN	!AA(Data)	Reads the Digital Input Counter	2.9
\$AA2	!AANNTTCCFF	Reads the Module Configuration	2.10
\$AA4	!S(Data)	Reads the Synchronized Data	2.11
\$AA5	!AAS	Reads the Reset Status	2.12
\$AA6	!(Data)	Reads the Digital I/O Status	2.13
\$AAC	!AA	Clears the Latched DI Status	2.14
\$AACN	!AA	Clears the Digital InputCounter	2.15
\$AAF	!AA(Data)	Reads the firmware Version	2.16
\$AALS	!(Data)	Reads the Latched DI Status	2.17
\$AAM	!AA(Data)	Reads the Module Name	2.18
\$AAP	!AASC	Reads the communication protocol	2.19
\$AAPN	!AA	Sets the communication protocol	2.20
@AA	>(Data)	Reads the Digital I/O Status	2.21
@AA(Data)	>	Sets the Digital Output Channels	2.22
~AAO(Name)	!AA	Sets the Module Name	2.23

Host Watchdog Command Sets			
Command	Response	Description	Section
~**	No Response	Host OK	2.24
~AA0	!AASS	Reads the Status	2.25
~AA1	!AA	Resets the Status	2.26
~AA2	!AAVV	Reads the Timeout Settings	2.27
~AA3EVV	!AA	Sets the Timeout Settings	2.28
~AA4V	!AA(Data)	Reads the PowerOn/Safe Value	2.29
~AA5V	!AA	Sets the PowerOn/Safe Value	2.30

2.1 %AANNTTCCFF

Description:

Sets the configuration of a module.

Syntax:

%AANNTTCCFF[CHKSUM](CR)

% Delimiter character

AA Address of the module to be configured in hexadecimal format (00 to FF)

NN New address of the module in hexadecimal format (00 to FF)

TT Type code, should be 40 for DIO module.

CC New Baud Rate code, see Section 1.9 for details. The INIT* pin must be connected to ground in order to change Baud Rates. For the module with frame ground, this is achieved by moving the rear slide switch to the INIT position. See Section A.1 for details.

FF Used to set the counter update direction and checksum (Section 1.9). The INIT* pin must be connected to ground in order to change the checksum setting. For the module with frame ground, this is achieved by moving the rear slide switch to the INIT position. See Section A.1 for details.

Response:

Valid Command: **!AA[CHKSUM](CR)**

Invalid Command: **?AA[CHKSUM](CR)**

! Delimiter for a valid command

? Delimiter for an invalid command. If the **Baud Rate** or **checksum** settings are changed without connecting the INIT* pin to ground or switching the rear slide switch to the INIT position, the module will return an invalid command.

AA Address of the module in hexadecimal format (00 to FF)

There will be no response if the command syntax is incorrect, there is a communication error, or there is no module with the specified address.

Examples:

Command: %0102400600 Response: !02

Changes the address of module 01 to 02. The module returns a valid response.

Command: %0101200A00 Response: ?01

Changes the Baud Rate of module 01 to 115200bps. The module returns an invalid command, because it is not in INIT* mode.

Command: %0101200A00 Response: !01

Changes the Baud Rate of module 01 to 115200bps and the module is in INIT* mode. The module returns a valid response.

Related Commands:

Section 2.10 \$AA2

Related Topics:

Section 1.9 Configuration Tables, Section A.1 INIT* pin Operation

Notes:

Changes to the address and counter update direction settings take effect immediately after a valid command is received.

Changes to the Baud Rate and checksum settings take effect on the next power-on reset.

2.2 #**

Description:

When the command is received, it will allow all modules to read data and will store the data for later retrieval.

Syntax:

#**[CHKSUM](CR)

Delimiter character

** Synchronized sampling command

Response:

There is no response with this command. To access the data, another command, \$AA4, must be sent, see Section 2.11 for details.

Examples:

Command: #** No response

Sends the synchronized sampling command.

Command: \$014 Response: !10F0000

Sends a command to read the synchronized data. The status byte of the response is 1, which means that it is the first time the synchronized data has been read after the previous #** command.

Command: \$014 Response: !00F0000

Sends a command to read the synchronized data. The status byte of the response is 0, which means that it is **NOT** the first time the synchronized data has been read after the previous #** command.

Related Commands:

Section 2.11 \$AA4

2.3 #AA00(Data)

Description:

Sets the digital output value of the lower eight channels.

Syntax:

#AA00(Data)[CHKSUM](CR)

#	Delimiter character
AA	Address of the module to be set (00 to FF)
00	Command to set the digital output value of the lower eight channels
(Data)	A two-digit hexadecimal value, where bit 0 corresponds to DO0, bit 1 corresponds to DO1, etc. When the bit is 1, it denotes that the digital output channel is on, and 0 denotes that the digital output channel is off.

Response:

Valid command: **>[CHKSUM](CR)**

Invalid command: **?[CHKSUM](CR)**

Ignored command: **![CHKSUM](CR)**

>	Delimiter character for a valid command
?	Delimiter character for an invalid command
!	Delimiter character for an ignored command. A host watchdog timeout has occurred, the digital output channels are set to safe value, and the digital output value that was sent is ignored.

There will be no response if the command syntax is incorrect, there is a communication error, or there is no module with the specified address.

Examples:

Command: #010033

Response: >

Sets DO0, DO1, DO4 and DO5 to on, and DO2, DO3, DO6, DO7 to off, and the module returns a valid response.

Related Commands:

Section 2.4 #AA0A(data), Section 2.5 #AA0B(data), Section 2.6 #AA1cDD, Section 2.7 #AAAcDD, Section 2.8 #AABcDD, Section 2.13 \$AA6, Section 2.21 @AA

Related Topics:

Section 1.10 DIO Active States

Notes:

1. This command is only applicable to the modules with digital output channels.
2. This command is the same as the #AA0A(Data) command.

2.4 #AA0A(Data)

Description:

Sets the digital output value of the lower eight channels.

Syntax:

#AA0A(Data)[CHKSUM](CR)

- # Delimiter character
- AA Address of the module to be set (00 to FF)
- 0A Command to set the digital output value of the lower eight channels
- (Data) A two-digit hexadecimal value, where bit 0 corresponds to DO0, bit 1 corresponds to DO1, etc. When the bit is 1, it denotes that the digital output channel is on, and 0 denotes that the digital output channel is off.

Response:

Valid command: **>[CHKSUM](CR)**

Invalid command: **?[CHKSUM](CR)**

Ignored command: **![CHKSUM](CR)**

- > Delimiter character for a valid command
- ? Delimiter character for an invalid command
- ! Delimiter character for an ignored command. A host watchdog timeout has occurred, the digital output channels are set to safe value, and the digital output value that was sent is ignored.

There will be no response if the command syntax is incorrect, there is a communication error, or there is no module with the specified address.

Examples:

Command: #010A33

Response: >

Sets DO0, DO1, DO4 and DO5 to on, and DO2, DO3, DO6, DO7 to off, and the module returns a valid response.

Related Commands:

Section 2.3 #AA00(data), Section 2.5 #AA0B(data), Section 2.6 #AA1cDD, Section 2.7 #AAAcDD, Section 2.8 #AABcDD, Section 2.13 \$AA6, Section 2.21 @AA

Related Topics:

Section 1.10 DIO Active States

Notes:

1. This command is only applicable to the modules with digital output channels.
2. This command is the same as the #AA00(Data) command.

2.5 #AA0B(Data)

Description:

Sets the digital output value of the upper eight channels.

Syntax:

#AA0B(Data)[CHKSUM](CR)

- # Delimiter character
- AA Address of the module to be set (00 to FF)
- 0B Command to set the digital output value of the upper eight channels
- (Data) A two-digit hexadecimal value, where bit 0 corresponds to DO8, bit 1 corresponds to DO9, etc. When the bit is 1, it denotes that the digital output channel is on, and 0 denotes that the digital output channel is off.

Response:

Valid command: >[CHKSUM](CR)

Invalid command: ?[CHKSUM](CR)

Ignored command: ![CHKSUM](CR)

- > Delimiter character for a valid command
- ? Delimiter character for an invalid command
- ! Delimiter character for an ignored command. A host watchdog timeout has occurred, the digital output ports are set to safe value, and the digital output value that was sent is ignored.

There will be no response if the command syntax is incorrect, there is a communication error, or there is no module with the specified address.

Examples:

Command: #010B33

Response: >

Sets DO8, DO9, DO12 and DO13 to on, and DO10, DO11, DO14, DO15 to off, and the module returns a valid response.

Related Commands:

Section 2.3 #AA00(data), Section 2.4 #AA0A(data), Section 2.6 #AA1cDD, Section 2.7 #AAAcDD, Section 2.8 #AABcDD, Section 2.13 \$AA6, Section 2.21 @AA

Related Topics:

Section 1.10 DIO Active States

Notes:

This command is only applicable to the modules with the number of digital output channels larger than eight.

2.6 #AA1cDD

Description:

Sets a single digital output channel of the lower eight channels.

Syntax:

#AA1cDD[CHKSUM](CR)

Delimiter character
AA Address of the module to be set (00 to FF)
1 Command to set a single digital output channel of the lower eight channels
c Specifies the digital output channel to be set (0 to 7).
DD 00: set the digital output channel to off.
01: set the digital output channel to on.

Response:

Valid command: **>[CHKSUM](CR)**

Invalid command: **?[CHKSUM](CR)**

Ignored command: **![CHKSUM](CR)**

> Delimiter character for a valid command
? Delimiter character for an invalid command
! Delimiter character for an ignored command. A host watchdog timeout has occurred, the digital output ports are set to safe value, and the digital output value that was sent is ignored.

There will be no response if the command syntax is incorrect, there is a communication error, or there is no module with the specified address.

Examples:

Command: #011201

Response: >

Sets DO2 to on, and the module returns a valid response.

Related Commands:

Section 2.3 #AA00(data), Section 2.4 #AA0A(data), Section 2.5 #AA0B(data), Section 2.7 #AAAcDD, Section 2.8 #AABcDD, Section 2.13 \$AA6, Section 2.21 @AA

Related Topics:

Section 1.10 DIO Active States

Notes:

1. This command is only applicable to the modules with digital output channels.
2. This command is the same as the #AAAcDD command.

2.7 #AAAcDD

Description:

Sets a single digital output channel of the lower eight channels.

Syntax:

#AAAcDD[CHKSUM](CR)

- # Delimiter character
- AA Address of the module to be set (00 to FF)
- A Command to set a single digital output channel of the lower eight channels
- c Specifies the digital output channel to be set (0 to 7).
- DD 00: set the digital output channel to off.
01: set the digital output channel to on.

Response:

Valid command: >[CHKSUM](CR)

Invalid command: ?[CHKSUM](CR)

Ignored command: ![CHKSUM](CR)

- > Delimiter character for a valid command
- ? Delimiter character for an invalid command
- ! Delimiter character for an ignored command. A host watchdog timeout has occurred, the digital output ports are set to safe value, and the digital output value that was sent is ignored.

There will be no response if the command syntax is incorrect, there is a communication error, or there is no module with the specified address.

Examples:

Command: #01A201

Response: >

Sets DO2 to on, and the module returns a valid response.

Related Commands:

Section 2.3 #AA00(data), Section 2.4 #AA0A(data), Section 2.5 #AA0B(data), Section 2.6 #AA1cDD, Section 2.8 #AABcDD, Section 2.13 \$AA6, Section 2.21 @AA

Related Topics:

Section 1.10 DIO Active States

Notes:

1. This command is only applicable to the modules with digital output channels.
2. This command is the same as the #AA1cDD command.

2.8 #AABcDD

Description:

Sets a single digital output channel of the upper eight channels.

Syntax:

#AABcDD[CHKSUM](CR)

Delimiter character

AA Address of the module to be set (00 to FF)

B Command to set a single digital output channel of the upper eight channels

c Specifies the digital output channel to be set (0 to 7), where 0 stands for channel 8, 1 stands for channel 9, etc.

DD 00: set the digital output channel to off.

01: set the digital output channel to on.

Response:

Valid command: >[CHKSUM](CR)

Invalid command: ?[CHKSUM](CR)

Ignored command: ![CHKSUM](CR)

> Delimiter character for a valid command

? Delimiter character for an invalid command

! Delimiter character for an ignored command. A host watchdog timeout has occurred, the digital output ports are set to safe value, and the digital output value that was sent is ignored.

There will be no response if the command syntax is incorrect, there is a communication error, or there is no module with the specified address.

Examples:

Command: #01B201 Response: >
 Sets DO10 to on, and the module returns a valid
 response.

Related Commands:

Section 2.3 #AA00(data), Section 2.4 #AA0A(data), Section
2.5 #AA0B(data), Section 2.6 #AA1cDD, Section 2.7
#AAAcDD, Section 2.13 \$AA6, Section 2.21 @AA

Related Topics:

Section 1.10 DIO Active States

Notes:

This command is only applicable to the modules with the number of digital output channels larger than eight.

2.9 #AAN

Description:

Reads the digital input counter of channel N.

Syntax:

#AAN[CHKSUM](CR)

Delimiter character

AA Address of the module to be read (00 to FF)

N The channel to be read (0 to F).

Response:

Valid Command: **!(Data)[CHKSUM](CR)**

Invalid Command: **?AA[CHKSUM](CR)**

! Delimiter character for a valid command

? Delimiter character for an invalid command. An invalid command is returned if the specified channel is incorrect.

(Data) Five decimal digits representing the digital input counter data of the specified channel (00000 to 65535).

AA Address of the responding module (00 to FF)

There will be no response if the command syntax is incorrect, there is a communication error, or there is no module with the specified address.

Examples:

Command: #032

Response: !0300103

Reads data from channel 2 of module 03 and the returned counter value is 103.

Command: #029

Response: ?02

Reads data from channel 9 of module 02. An error is returned because channel 9 is invalid.

Related Commands:

Section 2.15 \$AACN

Notes:

This command is only applicable to the module with digital inputs.

2.10 \$AA2

Description:

Reads the module configuration.

Syntax:

\$AA2[CHKSUM](CR)

\$ Delimiter character

AA Address of the module to be read (00 to FF)

2 Command to read the module configuration

Response:

Valid Command: **!AATCCFF[CHKSUM](CR)**

Invalid Command: **?AA[CHKSUM](CR)**

! Delimiter character for a valid command

? Delimiter character for an invalid command

AA Address of the responding module (00 to FF)

TT Type code of the module, should be 40 for DIO module.

CC Baud Rate code of the module, see Section 1.9 for details.

FF Checksum and counter update direction settings of the module, see Section 1.9 for details.

There will be no response if the command syntax is incorrect, there is a communication error, or there is no module with the specified address.

Examples:

Command: \$012

Response: !01400600

Reads the configuration of module 01.

Related Commands:

Section 2.1 %AANNTTCFF

Related Topics:

Section 1.9 Configuration Tables

2.11 \$AA4

Description:

Reads the synchronized data that was retrieved by the last #** command.

Syntax:

\$AA4[CHKSUM](CR)

\$ Delimiter character

AA Address of the module to be read (00 to FF)

4 Command to read the synchronized data

Response:

Valid Command: **!S(Data)[CHKSUM](CR)**

Invalid Command: **?AA[CHKSUM](CR)**

! Delimiter character for a valid command

? Delimiter character for an invalid command

AA Address of the responding module (00 to FF)

S Status of the synchronized data

1: first read

0: not the first read

(Data) Synchronized data. See Section 1.9 for the data format.

There will be no response if the command syntax is incorrect, there is a communication error, or there is no module with the specified address.

Examples:

Command: \$014

Response: ?01

Reads the synchronized data for module 01. An invalid command is returned because the #** command has not been issued in advance.

Command: #**

No response

Sends the synchronized sampling command.

Command: \$014

Response: !1000F00

Reads the synchronized data for module 01. The module returns the synchronized data and sets the status byte to 1 to indicate that this is the first time the synchronized data has been read.

Command: \$014

Response: !0000F00

Reads the synchronized data for module 01. The module returns the synchronized data and sets the status byte to 0 to indicate that the synchronized data has been read.

Related Commands:

Section 2.2 #**

2.12 \$AA5

Description:

Reads the reset status of a module.

Syntax:

\$AA5[CHKSUM](CR)

\$ Delimiter character

AA Address of the module to be read (00 to FF)

5 Command to read the module reset status

Response:

Valid Command: **!AAS[CHKSUM](CR)**

Invalid Command: **?AA[CHKSUM](CR)**

! Delimiter character for a valid command

? Delimiter character for an invalid command

AA Address of the responding module (00 to FF)

S Reset status of the module

1: This is the first time the command has been sent since the module was powered on.

0: This is not the first time the command has been sent since the module was powered on, which denotes that there has been no module reset since the last \$AA5 command was sent.

There will be no response if the command syntax is incorrect, there is a communication error, or there is no module with the specified address.

Examples:

Command: \$015

Response: !011

Reads the reset status of module 01. The response shows that it is the first time the \$AA5 command has been sent since the module was powered-on.

Command: \$015

Response: !010

Reads the reset status of module 01. The response shows that there has been no module reset since the last \$AA5 command was sent.

Related Topics:

Section A.4 Reset Status

2.13 \$AA6

Description:

Reads the status of the digital input/output channels.

Syntax:

\$AA6[CHKSUM](CR)

\$ Delimiter character

AA Address of the module to be read (00 to FF)

6 Command to read the digital input/output channels

Response:

Valid command: **!(Data)[CHKSUM](CR)**

Invalid command: **?AA[CHKSUM](CR)**

! Delimiter character for a valid command

? Delimiter character for an invalid command

AA Address of the responding module (00 to FF)

(Data) Status of the digital input/output channels, a four-digit hexadecimal value followed by 00. See Section 1.9 for details.

There will be no response if the command syntax is incorrect, there is a communication error, or there is no module with the specified address.

Examples:

Command: \$016

Response: !0F0000

Reads the digital input/output channel status of module 01 and returns 0F0000h, which denotes that RL1, RL2, RL3 and RL4 are on and IN1, IN2, IN3 and IN4 are off.

Related Commands:

Section 2.21 @AA

Related Topics:

Section 1.9 Configuration Tables

2.14 \$AAC

Description:

Clears the status of the latched digital input channels.

Syntax:

\$AAC[CHKSUM](CR)

\$ Delimiter character

AA Address of the module to be cleared (00 to FF)

C Command to clear the status of the latched digital input channels

Response:

Valid command: **!AA[CHKSUM](CR)**

Invalid command: **?AA[CHKSUM](CR)**

! Delimiter character for a valid command

? Delimiter character for an invalid command

AA Address of the responding module (00 to FF)

There will be no response if the command syntax is incorrect, there is a communication error, or there is no module with the specified address.

Examples:

Command: \$01L0

Response: !FFFF00

Sends the command to read the status of the low latched digital input channels of module 01 and returns FFFF.

Command: \$01C

Response: !01

Sends the command to clear the status of the latched digital input channels of module 01 and returns a valid response.

Command: \$01L0

Response: !000000

Sends the command to read the status of the low latched digital input channels of module 01 and returns 0000.

Related Commands:

Section 2.17 \$AALS

Notes:

1. This command is only applicable to the modules with digital input channels.
2. Both the status of the low and high latched digital input channels are cleared.

2.15 \$AACN

Description:

Clears the digital input counter of channel N.

Syntax:

\$AACN[CHKSUM](CR)

\$ Delimiter character
AA Address of the module to be cleared (00 to FF)
C Command to clear the digital input counter
N The channel to be cleared (0 to F).

Response:

Valid Command: **!AA[CHKSUM](CR)**
Invalid Command: **?AA[CHKSUM](CR)**
! Delimiter character for a valid command
? Delimiter character for an invalid command. An invalid command is returned if the specified channel is incorrect.
AA Address of the responding module (00 to FF)

There will be no response if the command syntax is incorrect, there is a communication error, or there is no module with the specified address.

Examples:

Command: #032

Response: !0300103

Reads counter data from channel 2 of module 03 and the returned counter value is 103.

Command: \$03C2

Response: !03

Clears the counter value of channel 2 of module 03 and returns a valid response.

Command: #032

Response: !0300000

Reads counter data from channel 2 of module 03 and the returned counter value is 3.

Related Commands:

Section 2.9 #AAN

Notes:

This command is only applicable to the module with digital inputs.

2.16 \$AAF

Description:

Reads the firmware version of a module.

Syntax:

\$AAF[CHKSUM](CR)

\$ Delimiter character

AA Address of the module to be read (00 to FF)

F Command to read the firmware version

Response:

Valid command: **!AA(Data)[CHKSUM](CR)**

Invalid command: **?AA[CHKSUM](CR)**

! Delimiter character for a valid command

? Delimiter character for an invalid command

AA Address of the responding module (00 to FF)

(Data) Firmware version string of the module

There will be no response if the command syntax is incorrect, there is a communication error, or there is no module with the specified address.

Examples:

Command: \$01F

Response: !01A2.0

Reads the firmware version of module 01, and shows that it is version A2.0.

Command: \$02F

Response: !02B1.1

Reads the firmware version of module 02, and shows that it is version B1.1.

2.17 \$AALS

Description:

Reads the status of the latched digital input channels.

Syntax:

\$AALS[CHKSUM](CR)

\$ Delimiter character
AA Address of the module to be read (00 to FF)
L Command to read the latched status
S 0: read the low latched status
 1: read the high latched status

Response:

Valid command: **!(Data)[CHKSUM](CR)**

Invalid command: **?AA[CHKSUM](CR)**

! Delimiter character for a valid command
? Delimiter character for an invalid command
AA Address of the responding module (00 to FF)
(Data) Status of the latched digital input channels, a four-digit hexadecimal value followed by 00. See Section 1.9 for details.

There will be no response if the command syntax is incorrect, there is a communication error, or there is no module with the specified address.

Examples:

Command: \$01L0

Response: !01FFFF00

Sends the command to read the status of the low latched digital input channels of module 01 and returns FFFF.

Command: \$01C

Response: !01

Sends the command to clear the status of the latched digital input channels of module 01 and returns a valid response.

Command: \$01L0

Response: !01000000

Sends the command to read the status of the low latched digital input channels of module 01 and returns 0000.

Related Commands:

Section 2.14 \$AAC

Related Topics:

Section 1.9 Configuration Tables

Notes:

This command is only applicable to the modules with digital input channels.

2.18 \$AAM

Description:

Reads the name of a module.

Syntax:

\$AAM[CHKSUM](CR)

\$ Delimiter character

AA Address of the module to be read (00 to FF)

M Command to read the module name

Response:

Valid command: **!AA(Data)[CHKSUM](CR)**

Invalid command: **?AA[CHKSUM](CR)**

! Delimiter character for a valid command

? Delimiter character for an invalid command

AA Address of the responding module (00 to FF)

(Name) Name string of the module

There will be no response if the command syntax is incorrect, there is a communication error, or there is no module with the specified address.

Examples:

Command: \$01M

Response: !01tP4C4

Reads the module name of module 01 and returns the name "tP4C4".

Related Commands:

Section 2.23 ~AAO(Name)

2.19 \$AAP

Description:

Reads the communication protocol information.

Syntax:

\$AAP[CHKSUM](CR)

\$ Delimiter character

AA Address of the module to be read (00 to FF)

P Command to read the communication protocol

Response:

Valid Response: !AASC[CHKSUM](CR)

Invalid Response: ?AA[CHKSUM](CR)

! Delimiter character for a valid response

? Delimiter character for an invalid response

AA Address of the responding module (00 to FF)

S The protocols supported by the module

0: only DCON protocol is supported

1: both the DCON and Modbus RTU protocols are supported

3: all of the DCON and Modbus RTU/ASCII protocols are supported

C The current protocol that is saved in the EEPROM that will be used at the next power-on reset

0: the protocol set in the EEPROM is DCON

1: the protocol set in the EEPROM is Modbus RTU

3: the protocol set in the EEPROM is Modbus ASCII

There will be no response if the command syntax is incorrect, there is a communication error, or there is no module with the specified address.

Examples:

Command: \$01P

Response: !0110

Reads the communication protocol of module 01 and returns a response of 10 meaning that it supports both the DCON and Modbus RTU protocols and the protocol that will be used at the next power-on reset is DCON.

Related Commands:

Section 2.20 \$AAPN

2.20 \$AAPN

Description:

Sets the communication protocol.

Syntax:

\$AAPN[CHKSUM](CR)

\$ Delimiter character

AA Address of the module to be read (00 to FF)

P Command to set the communication protocol

N 0: DCON protocol

1: Modbus RTU protocol

3: Modbus ASCII protocol

Before using this command, the rear slide switch must be in the INIT position. The new protocol is saved in the EEPROM and will be effective after the next power-on reset.

Response:

Valid Response: !AASC[CHKSUM](CR)

Invalid Response: ?AA[CHKSUM](CR)

! Delimiter character for a valid response

? Delimiter character for an invalid response

AA Address of the responding module (00 to FF)

There will be no response if the command syntax is incorrect, there is a communication error, or there is no module with the specified address.

Examples:

Command: \$01P1

Response: ?01

Sets the communication protocol of module 01 to Modbus RTU and returns an invalid response because the module is not in INIT mode.

Command: \$01P1

Response: !01

Sets the communication protocol of module 01 to Modbus RTU and returns a valid response.

Related Commands:

Section 2.19 \$AAP

2.21 @AA

Description:

Reads the status of the digital input/output ports.

Syntax:

@AA[CHKSUM](CR)

@ Delimiter character

AA Address of the module to be read (00 to FF)

Response:

Valid command: **>(Data)[CHKSUM](CR)**

Invalid command: **?AA[CHKSUM](CR)**

> Delimiter character for a valid command

? Delimiter character for an invalid command or invalid type code

AA Address of the responding module (00 to FF)

(Data) Status of the digital input/output ports, a four-digit hexadecimal value. See Section 1.9 for details.

There will be no response if the command syntax is incorrect, there is a communication error, or there is no module with the specified address.

Examples:

Command: @01

Response: >0F00

Reads the digital input/output port status of module 01 and returns 0F00h, which denotes that RL1, RL2, RL3 and RL4 are on and IN1, IN2, IN3 and IN4 are off.

Related Commands:

Section 2.13 \$AA6

Related Topics:

Section 1.9 Configuration Tables

2.22 @AA(Data)

Description:

Sets the digital output channels.

Syntax:

@AA(Data)[CHKSUM](CR)

@ Delimiter character

AA Address of the module to be set (00 to FF)

(Data) Data to be written to the digital output channels.

For the tM-P4C4, it is a one-digit hexadecimal value. For the tM-C8, it is a two-digit hexadecimal value. Bit 0 of the value corresponds to DO0 and bit 1 of the value corresponds to DO1, etc. When the bit is 1, it denotes that the digital output channel is on, and 0 denotes that the digital output channel is off.

Response:

Valid command: >[CHKSUM](CR)

Invalid command: ?[CHKSUM](CR)

Ignored command: ![CHKSUM](CR)

> Delimiter character for a valid command

? Delimiter character for an invalid command

! Delimiter character for an ignored command. A host watchdog timeout has occurred, the digital output ports are set to safe value, and the digital output value that was sent is ignored.

There will be no response if the command syntax is incorrect, there is a communication error, or there is no module with the specified address.

Examples:

Command: @017 Response: >

For the tM-P4C4 module, sets DO0 to on, DO1 to on, DO2 to on, and DO3 to off, and the module returns a valid response.

Command: @0207 Response: >

For the tM-C8 module, sets DO0 to on, DO1 to on, DO2 to on, and other channels to off, and the module returns a valid response.

Related Commands:

Section 2.21 @AA

Related Topics:

Section 1.10 DIO Active States

Notes:

This command is only applicable to the modules with digital output channels.

2.23 ~AAO(Name)

Description:

Sets the name of a module.

Syntax:

~AAO(Name)[CHKSUM](CR)

~ Delimiter character

AA Address of the module to be set (00 to FF)

O Command to set the module name

(Name) New name of the module (max. 6 characters).

Response:

Valid command: **!AA[CHKSUM](CR)**

Invalid command: **?AA[CHKSUM](CR)**

! Delimiter character for a valid command

? Delimiter character for an invalid command

AA Address of the responding module (00 to FF)

There will be no response if the command syntax is incorrect, there is a communication error, or there is no module with the specified address.

Examples:

Command: ~01O7050N

Response: !01

Sets the name of module 01 to be “7050N” and returns a valid response.

Command: \$01M

Response: !017050N

Reads the name of module 01 and returns the name “7050N”.

Related Commands:

Section 2.18 \$AAM

2.25 ~AA0

Description:

Reads the host watchdog status of a module.

Syntax:

~AA0[CHKSUM](CR)

- ~ Delimiter character
- AA Address of the module to be read (00 to FF)
- 0 Command to read the module status

Response:

Valid command: **!AASS[CHKSUM](CR)**

Invalid command: **?AA[CHKSUM](CR)**

- ! Delimiter character for a valid command
 - ? Delimiter character for an invalid command
 - AA Address of the responding module (00 to FF)
 - SS Two hexadecimal digits that represent the host watchdog status, where:
 - Bit 7: 0 indicates that the host watchdog is disabled, and 1 indicates that the host watchdog is enabled,
 - Bit 2: 1 indicates that a host watchdog timeout has occurred, and 0 indicates that no host watchdog timeout has occurred.
- The host watchdog status is stored in EEPROM and can only be reset by using the ~AA1 command.

There will be no response if the command syntax is incorrect, there is a communication error, or there is no module with the specified address.

Examples:

Command: ~010

Response: !0100

Reads the host watchdog status of module 01 and returns 00, meaning that the host watchdog is disabled and no host watchdog timeout has occurred.

Command: ~020

Response: !0204

Reads the host watchdog status of module 02 and returns 04, meaning that a host watchdog timeout has occurred.

Related Commands:

Section 2.24 ~**, Section 2.26 ~AA1, Section 2.27 ~AA2, Section 2.28 ~AA3EVV, Section 2.29 ~AA4V, Section 2.30 ~AA5V

Related Topics:

Section A.2 Dual Watchdog Operation

2.26 ~AA1

Description:

Resets the host watchdog timeout status of a module.

Syntax:

~AA1[CHKSUM](CR)

~ Delimiter character

AA Address of the module to be reset (00 to FF)

1 Command to reset the host watchdog timeout status

Response:

Valid command: **!AA[CHKSUM](CR)**

Invalid command: **?AA[CHKSUM](CR)**

! Delimiter character for a valid command

? Delimiter character for an invalid command

AA Address of the responding module (00 to FF)

There will be no response if the command syntax is incorrect, there is a communication error, or there is no module with the specified address.

Examples:

Command: ~010

Response: !0104

Reads the host watchdog status of module 01 and shows that a host watchdog timeout has occurred.

Command: ~011

Response: !01

Resets the host watchdog timeout status of module 01 and returns a valid response.

Command: ~010

Response: !0100

Reads the host watchdog status of module 01 and shows that no host watchdog timeout has occurred.

Related Commands:

Section 2.24 ~**, Section 2.25 ~AA0, Section 2.27 ~AA2, Section 2.28 ~AA3Evv, Section 2.29 ~AA4V, Section 2.30 ~AA5V

Related Topics:

Section A.2 Dual Watchdog Operation

2.27 ~AA2

Description:

Reads the host watchdog timeout value of a module.

Syntax:

~AA2[CHKSUM](CR)

~ Delimiter character

AA Address of the module to be read (00 to FF)

2 Command to read the host watchdog timeout value

Response:

Valid command : **!AAEVV[CHKSUM](CR)**

Invalid command: **?AA[CHKSUM](CR)**

! Delimiter character for a valid command

? Delimiter character for an invalid command

AA Address of the responding module (00 to FF)

E 1: the host watchdog is enabled

0: the host watchdog is disabled

VV Two hexadecimal digits to represent the timeout value in tenths of a second, for example, 01 denotes 0.1 seconds and FF denotes 25.5 seconds.

There will be no response if the command syntax is incorrect, there is a communication error, or there is no module with the specified address.

Examples:

Command: ~012

Response: !011FF

Reads the host watchdog timeout value of module 01 and returns FF, which denotes that the host watchdog is enabled and the host watchdog timeout value is 25.5 seconds.

Related Commands:

Section 2.24 ~**, Section 2.25 ~AA0, Section 2.26 ~AA1, Section 2.28 ~AA3Evv, Section 2.29 ~AA4V, Section 2.30 ~AA5V

Related Topics:

Section A.2 Dual Watchdog Operation

2.28 ~AA3E VV

Description:

Enables/disables the host watchdog and sets the host watchdog timeout value of a module.

Syntax:

~AA3E VV[CHKSUM](CR)

~	Delimiter character
AA	Address of the module to be set (00 to FF)
3	Command to set the host watchdog
E	1: enable the host watchdog 0: disable the host watchdog
VV	Two hexadecimal digits to represent the timeout value in tenths of a second, for example, 01 denotes 0.1 seconds and FF denotes 25.5 seconds.

Response:

Valid command: **!AA[CHKSUM](CR)**

Invalid command: **?AA[CHKSUM](CR)**

!	Delimiter character for a valid command
?	Delimiter character for an invalid command
AA	Address of the responding module (00 to FF)

There will be no response if the command syntax is incorrect, there is a communication error, or there is no module with the specified address.

Examples:

Command: ~013164

Response: !01

Enables the host watchdog of module 01 and sets the host watchdog timeout value to 10.0 seconds. The module returns a valid response.

Command: ~012

Response: !01164

Reads the host watchdog timeout value of module 01. The module returns 164, which denotes that the host watchdog is enabled and the host watchdog timeout value is 10.0 seconds.

Related Commands:

Section 2.24 ~**, Section 2.25 ~AA0, Section 2.26 ~AA1, Section 2.27 ~AA2, Section 2.29 ~AA4V, Section 2.30 ~AA5V

Related Topics:

Section A.2 Dual Watchdog Operation

Notes:

When a host watchdog timeout occurs, the host watchdog is disabled. The ~AA3EVV command should be sent again to reenable the host watchdog.

2.29 ~AA4V

Description:

Reads the power-on DO value or the safe DO value of a module.

Syntax:

~AA4V[CHKSUM](CR)

- ~ Delimiter character
- AA Address of the module to be read (00 to FF)
- 4 Command to read the power-on DO value or the safe DO value
- V P: Reads the power-on DO value
S: Reads the safe DO value

Response:

Valid command : **!AA(Data)[CHKSUM](CR)**

Invalid command: **?AA[CHKSUM](CR)**

- ! Delimiter character for a valid command
- ? Delimiter character for an invalid command
- AA Address of the responding module (00 to FF)
- (Data) Power-on DO value or safe DO value.
They are two hexadecimal digits followed by 00.

There will be no response if the command syntax is incorrect, there is a communication error, or there is no module with the specified address.

Examples:

Command: ~014S

Response: !010000

Reads the safe DO value of module 01 and returns 0000.

Command: ~014P

Response: !01FF00

Reads the power-on DO value of module 01 and returns FF00.

Related Commands:

Section 2.30 ~AA5V

Related Topics:

Section 1.10 DIO Active States, Section A.2 Dual Watchdog Operation

Notes:

This command is only applicable to the modules with digital output channels.

2.30 ~AA5V

Description:

Sets the current DO value as the power-on DO value or the safe DO value.

Syntax:

~AA5V[CHKSUM](CR)

- ~ Delimiter character
- AA Address of the module to be set (00 to FF)
- 5 Command to set the power-on value or the safe DO value
- V P: Sets the power-on DO value
S: Sets the safe DO value

Response:

Valid command: **!AA[CHKSUM](CR)**

Invalid command: **?AA[CHKSUM](CR)**

- ! Delimiter character for a valid command
- ? Delimiter character for an invalid command
- AA Address of the responding module (00 to FF)

There will be no response if the command syntax is incorrect, there is a communication error, or there is no module with the specified address.

Examples:

Command: @01AA Response: >
Sets the DO value of module 01 to AA and the module returns a valid response.

Command: ~015P Response: !01
Sets the power-on DO value and the module returns a valid response.

Command: @0155 Response: >
Sets the DO value of module 01 to 55 and the module returns a valid response.

Command: ~015S Response: !01
Sets the safe DO value and the module returns a valid response.

Command: ~014P Response: !01AA00
Reads the power-on DO value of module 01. The module returns AA00, which denotes that the power-on DO value is AA.

Command: ~014S Response: !015500
Reads the safe DO value of module 01. The module returns 5500, which denotes that the safe DO value is 55.

Related Commands:

Section 2.29 ~AA4V

Related Topics:

Section A.2 Dual Watchdog Operation

Notes:

This command is only applicable to the modules with the digital output channels.

2.31 ~AAD

Description:

Reads the miscellaneous settings of a module.

Syntax:

~AAD[CHKSUM](CR)

~ Delimiter character

AA Address of the module to be read (00 to FF)

D Command to read the miscellaneous settings

Response:

Valid Command: !AAT[CHKSUM](CR)

Invalid Command: ?AA[CHKSUM](CR)

! Delimiter character for a valid command

? Delimiter character for an invalid command

AA Address of the responding module (00 to FF)

VV Two hexadecimal digits that represent the miscellaneous settings as follows:

7	6	5	4	3	2	1	0
Reserved						0A	IA

Key	Description
0A	DO active state 0: output value 1 for relay active output value 0 for relay inactive 1: output value 0 for relay active output value 1 for relay inactive
IA	DI active state 0: input value 1 for non-signal or the low voltage; input value 0 for high voltage 1: input value 0 for non-signal or the low voltage; input value 1 for high voltage

There will be no response if the command syntax is incorrect, there is a communication error, or there is no module with the specified address.

Examples:

Command: ~01D

Response: !0101

Reads the miscellaneous settings of module 01 and returns 01.

Related Commands:

Section 2.32 ~AADVV

2.32 ~AADVV

Description:

Sets the miscellaneous settings of a module.

Syntax:

~AADVV[CHKSUM](CR)

- ~ Delimiter character
- AA Address of the module to be set (00 to FF)
- D Command to set the miscellaneous settings
- VV Two hexadecimal digits that represent the miscellaneous settings as follows:

7	6	5	4	3	2	1	0
Reserved						OA	IA

Key	Description
OA	DO active state 0: output value 1 for relay active output value 0 for relay inactive 1: output value 0 for relay active output value 1 for relay inactive
IA	DI active state 0: input value 1 for non-signal or the low voltage; input value 0 for high voltage 1: input value 0 for non-signal or the low voltage; input value 1 for high voltage

Response:

Valid Command: !**AA**[**CHKSUM**](**CR**)

Invalid Command: ?**AA**[**CHKSUM**](**CR**)

! Delimiter character for a valid command

? Delimiter character for an invalid command

AA Address of the responding module (00 to FF)

There will be no response if the command syntax is incorrect, there is a communication error, or there is no module with the specified address.

Examples:

Command: ~01D01

Response: !01

Sets the miscellaneous settings of module 01 to 01,
and returns a valid response.

Related Commands:

Section 2.31 ~AAD

2.33 ~AARD

Description:

Reads the response delay time value of a module.

Syntax:

~AARD[CHKSUM](CR)

~ Delimiter character

AA Address of the module to be read (00 to FF)

RD Command to read the response delay time value

Response:

Valid command : **!AAVV[CHKSUM](CR)**

Invalid command: **?AA[CHKSUM](CR)**

! Delimiter character for a valid command

? Delimiter character for an invalid command

AA Address of the responding module (00 to FF)

VV Two hexadecimal digits to represent the response delay time value in milli-second, for example, 01 denotes 1ms and 1E denotes 30ms. The max allowable value is 30 (1Eh).

There will be no response if the command syntax is incorrect, there is a communication error, or there is no module with the specified address.

Examples:

Command: ~01RD

Response: !0102

Reads the response delay time value of module 01 and returns 02, which denotes that the response delay time value is 2ms.

Related Commands:

Section 2.34 ~AARDVV

2.34 ~AARDVV

Description:

Sets the response delay time value of a module.

Syntax:

~AARDVV[CHKSUM](CR)

- ~ Delimiter character
- AA Address of the module to be set (00 to FF)
- RD Command to set the response delay time
- VV Two hexadecimal digits to represent the response delay time value in milli-second, for example, 01 denotes 1ms and 1E denotes 30s. The max allowable value is 30 (1Eh).

Response:

Valid command: **!AA[CHKSUM](CR)**

Invalid command: **?AA[CHKSUM](CR)**

- ! Delimiter character for a valid command
- ? Delimiter character for an invalid command
- AA Address of the responding module (00 to FF)

There will be no response if the command syntax is incorrect, there is a communication error, or there is no module with the specified address.

Examples:

Command: ~01RD06

Response: !01

Sets the response delay time value to 6ms. The module returns a valid response.

Command: ~01RD

Response: !0106

Reads the response delay time value of module 01. The module returns 06, which denotes that the response delay time value is 6ms.

Related Commands:

Section 2.33 ~AARD

3. Modbus RTU Protocol

The Modbus protocol is developed by Modicon Inc., originally developed for Modicon controllers. Detailed information can be found at <http://www.modicon.com/techpubs/toc7.html>. You can also visit <http://www.modbus.org> to find more valuable information.

tM series modules support the Modbus RTU protocol. The communication Baud Rates range from 1200bps to 115200bps. The following Modbus functions are supported.

Function code	Description	Section
01 (0x01)	Read coils	3.1
02 (0x02)	Read discrete inputs	3.2
03 (0x03)	Read multiple registers	3.3
04 (0x04)	Read multiple input registers	3.4
05 (0x05)	Write single coil	3.5
15 (0x0F)	Write multiple coils	3.6
70 (0x46)	Read/write module settings	3.7

If the function specified in the message is not supported, then the module responds as follows.

Error Response

00	Address	1 Byte	1 to 247
01	Function code	1 Byte	Function code + 0x80
02	Exception code	1 Byte	01

If a CRC mismatch occurs, the module will not respond.

3.1 01 (0x01) Read Coils

This function code is used to read the current digital output readback value of the tM module.

Request

00	Address	1 Byte	1 ~ 247
01	Function code	1 Byte	0x01
02 ~ 03	Starting channel numbers	2 Bytes	0x0000~0x001F for DO readback value 0x0020~0x003F for DI value 0x0040~0x005F for DIO Latch high value 0x0060~0x007F for DIO Latch low value
04 ~ 05	Output channel number	2 Bytes	0x0001 ~ 0x001F

Response

00	Address	1 Byte	1 ~ 247
01	Function code	1 Byte	0x01
02	Byte count	1 Byte	1
03	Output channel readback value	1 Byte	Refer to the Supported Modules section for the details of the value

Error Response

00	Address	1 Byte	1 ~ 247
01	Function code	1 Byte	0x81
02	Exception code	1 Byte	Refer to the Modbus standard for more details.

Supported Modules

tM-P4C4:

Valid starting channel	0x0000~0x0003 for DO readback value
	0x0020~0x0023 for DI value
	0x0040~0x0043 for DI Latch high value
	0x0048~0x004B for DO Latch high value
	0x0060~0x0063 for DI Latch low value 0x0068~0x006B for DO Latch low value

tM-C8:

Valid starting channel	0x0000~0x0007 for DO readback value
	0x0040~0x0047 for DO Latch high value
	0x0060~0x0067 for DO Latch low value

tM-P8:

Valid starting channel	0x0020~0x0027 for DI value
	0x0040~0x0047 for DI Latch high value
	0x0060~0x0067 for DI Latch low value

3.2 02 (0x02) Read Discrete Inputs

This function code is used to read the current digital input value of the tM module.

Request

00	Address	1 Byte	1 ~ 247
01	Function code	1 Byte	0x02
02 ~ 03	Starting channel	2 Bytes	0x0020 ~ 0x003F
04 ~ 05	Input channel number	2 Bytes	0x0001 ~ 0x0020

Response

00	Address	1 Byte	1 ~ 247
01	Function code	1 Byte	0x02
02	Byte count	1 Byte	1
03	Input channel data	1 Byte	Refer to the Supported Modules section for details of the value.

Error Response

00	Address	1 Byte	1 ~ 247
01	Function code	1 Byte	0x82
02	Exception code	1 Byte	Refer to the Modbus standard for more details.

Supported Modules

tM-P4C4:

Valid starting channel	0x0020~0x0023 for DI value
------------------------	----------------------------

tM-P8:

Valid starting channel	0x0020~0x0027 for DI value
------------------------	----------------------------

3.3 03 (0x03) Read Multiple Registers

This function code is used to read the current digital input counter value of the tM module.

Request

00	Address	1 Byte	1 ~ 247
01	Function code	1 Byte	0x03
02 ~ 03	Starting channel numbers	2 Bytes	0x0000 ~ 0x001F
04 ~ 05	Input channel number	2 Bytes	0x0001 ~ 0x0020

Response

00	Address	1 Byte	1 ~ 247
01	Function code	1 Byte	0x03
02	Byte count	1 Byte	1
03~	Input channel counter value	*N x 2 Bytes	Each channel can record a maximum counter value up to 65535 (0xFFFF).

*N = Number of input channels

Error Response

00	Address	1 Byte	1 ~ 247
01	Function code	1 Byte	0x83
02	Exception code	1 Byte	Refer to the Modbus standard for more details.

Supported Modules

tM-P4C4:

Valid starting channel	0x0000~0x0003 for DI counter value
------------------------	------------------------------------

tM-P8:

Valid starting channel	0x0000~0x0007 for DI counter value
------------------------	------------------------------------

3.4 04 (0x04) Read Multiple Input Registers

This function code is used to read the current digital input counter value of the tM module.

Request

00	Address	1 Byte	1 ~ 247
01	Function code	1 Byte	0x04
02 ~ 03	Starting channel numbers	2 Bytes	0x0000 ~ 0x001F
04 ~ 05	Input channel number	2 Bytes	0x0001 ~ 0x0020

Response

00	Address	1 Byte	1 ~ 247
01	Function code	1 Byte	0x04
02	Byte count	1 Byte	1
03~	Input channel counter value	*N x 2 Bytes	Each channel can record the maximum counter value up to 65535 (0xFFFF).

*N = Number of input channels

Error Response

00	Address	1 Byte	1 ~ 247
01	Function code	1 Byte	0x84
02	Exception code	1 Byte	Refer to the Modbus standard for more details.

Supported Modules

tM-P4C4:

Valid starting channel	0x0000~0x0003 for DI counter value
------------------------	------------------------------------

tM-P8:

Valid starting channel	0x0000~0x0007 for DI counter value
------------------------	------------------------------------

3.5 05 (0x05) Write Single Coils

This function code is used to write the digital output value of the tM module.

Request

00	Address	1 Byte	1 ~ 247
01	Function code	1 Byte	0x05
02 ~ 03	Output channel numbers	2 Bytes	0x0000 ~ 0x001F 0x0107 to clear the latch value 0x0200~0x0220 to clear the DI counter value
04 ~ 05	Output value	2 Bytes	A value of 0xFF00 sets the output to ON. A value of 0x0000 sets it to OFF. All other values are illegal and will not affect the coil.

Response

00	Address	1 Byte	1 ~ 247
01	Function code	1 Byte	0x05
02 ~ 03	Output channel numbers	2 Bytes	The value is the same as byte 02 and 03 of the Request
04 ~ 05	Output value	2 Bytes	The value is the same as byte 04 and 05 of the Request

Error Response

00	Address	1 Byte	1 ~ 247
01	Function code	1 Byte	0x85
02	Exception code	1 Byte	Refer to the Modbus standard for more details.

Supported Modules

tM-P4C4:

Valid output channel	0x0000~0x0003 for DO output
	0x0107 to clear the DIO latch value. If setting this channel to ON, the latch value will become 0.
	0x0200~0x0203 to clear the DI counter value

tM-C8:

Valid output channel	0x0000~0x 0007 for DO output
	0x0107 to clear the DIO latch value. If setting this channel to ON, the latch value will become 0.
	0x0200~0x0207 to clear the DI counter value

tM-P8:

Valid output channel	0x0107 to clear the DI latch value. If setting this channel to ON, the latch value will become 0.
	0x0200~0x0207 to clear the DI counter value

3.6 15 (0x0F) Write Multiple Coils

This function code is used to write the digital output value of the tM module.

Request

00	Address	1 Byte	1 ~ 247
01	Function code	1 Byte	0x0F
02 ~ 03	Starting channel numbers	2 Bytes	0x0000 ~ 0x001F for DO output 0x0200~0x0220 to clear the DI count value
04 ~ 05	Output channel number	2 Bytes	0x0001 ~ 0x0020
06	Byte count	1 Byte	1
07	Output value	1 Byte	A bit corresponds to a channel. When the bit is 1 it denotes that the value of the channel that was set is ON. If the bit is 0 it denotes that the value of the channel that was set is OFF.

Response

00	Address	1 Byte	1 ~ 247
01	Function code	1 Byte	0x0F
02 ~ 03	Starting channel numbers	2 Bytes	The value is the same as byte 02 and 03 of the Request
04 ~ 05	Input channel number	2 Bytes	The value is the same as byte 04 and 05 of the Request

Error Response

00	Address	1 Byte	1 ~ 247
01	Function code	1 Byte	0x8F
02	Exception code	1 Byte	Refer to the Modbus standard for more details.

Supported Modules

tM-P4C4:

Valid starting channel	0x0000~0x0003 for DO output
	0x0200~0x0203 to clear the DI counter value

tM-C8:

Valid starting channel	0x0000~0x0007 for DO output
------------------------	-----------------------------

tM-P8:

Valid starting channel	0x0200~0x0207 to clear the DI counter value
------------------------	---

3.7 70 (0x46) Read/Write Module Settings

This function code is used to read the settings of the module or change the settings of the module. The following sub-function codes are supported.

Sub-function Code	Description	Section
00 (0x00)	Read the module name	3.7.1
04 (0x04)	Set the module address	3.7.2
05 (0x05)	Read the communication settings	3.7.3
06 (0x06)	Set the communication settings	3.7.4
32 (0x20)	Read the firmware version	3.7.5
33 (0x21)	Set the DI counter edge	3.7.6
34 (0x22)	Read the DI counter edge setting value	3.7.7
39 (0x27)	Set the DO power-on value	3.7.8
40 (0x28)	Read the DO power-on value	3.7.9
41 (0x29)	Set the DI/O active states	3.7.10
42 (0x2A)	Read the DI/O active states	3.7.11

If the module does not support the sub-function code specified in the message, then it responds as follows:

Error Response

00	Address	1 Byte	1 ~ 247
01	Function code	1 Byte	0xC6
02	Exception code	1 Byte	Refer to the Modbus standard for more details.

3.7.1 Sub-function 00 (0x00) Read module name

This sub-function code is used to read the name of a module.

Request

00	Address	1 Byte	1 ~ 247
01	Function code	1 Byte	0x46
02	Sub-function code	1 Byte	0x00

Response

00	Address	1 Byte	1 ~ 247
01	Function code	1 Byte	0x46
02	Sub-function code	1 Byte	0x00
03 ~ 06	Module name	4 Bytes	0x07 0x44 0x00 0x00 for tM-P4C4 0x07 0x08 0x00 0x00 for tM-C8 0x07 0x80 0x00 0x00 for tM-P8

Error Response

00	Address	1 Byte	1 ~ 247
01	Function code	1 Byte	0xC6
02	Exception code	1 Byte	Refer to the Modbus standard for more details.

3.7.2 Sub-function 04 (0x04) Set module address

This sub-function code is used to set the address of a module.

Request

00	Address	1 Byte	1 ~ 247
01	Function code	1 Byte	0x46
02	Sub-function code	1 Byte	0x04
03	Address	1 Byte	1 ~ 247
04~ 06	Reserved	3 Bytes	0x00 0x00 0x00

Response

00	Address	1 Byte	1 ~ 247
01	Function code	1 Byte	0x46
02	Sub-function code	1 Byte	0x04
03	Set address result	1 Byte	0x00: OK Others: error
04~ 06	Reserved	3 Bytes	0x00 0x00 0x00

Error Response

00	Address	1 Byte	1 ~ 247
01	Function code	1 Byte	0xC6
02	Exception code	1 Byte	Refer to the Modbus standard for more details.

3.7.3 Sub-function 05 (0x05) Read communication settings

This sub-function code is used to read the communication protocol settings of a module.

Request

00	Address	1 Byte	1 ~ 247
01	Function code	1 Byte	0x46
02	Sub-function code	1 Byte	0x05
03	Reserved	1 Byte	0x00

Response

00	Address	1 Byte	1 ~ 247
01	Function code	1 Byte	0x46
02	Sub-function code	1 Byte	0x05
03	Protocol supported	1 Byte	0x00: Modbus RTU 0x03: Modbus RTU & ASCII
04	Baud Rate	1 Byte	Baud rate code, see Section 1.9 for details.
05	Reserved	1 Byte	0x00
06	Data format	1 Byte	0x00: no parity, 1 stop bit 0x01: no parity, 2 stop bits 0x02: even parity, 1 stop bit 0x03: odd parity, 1 stop bit
07	Reserved	1 Byte	0x00
08	Mode	1 Byte	0x00: DCON protocol 0x01: Modbus RTU protocol 0x03: Modbus ASCII protocol
09~10	Reserved	2 Bytes	0x00 0x00

Note: This information is the data saved in the EEPROM and will be used for the next power-on reset. It is not the currently used settings.

Error Response

00	Address	1 Byte	1 ~ 247
01	Function code	1 Byte	0xC6
02	Exception code	1 Byte	Refer to the Modbus standard for more details.

3.7.4 Sub-function 06 (0x06) Set communication settings

This sub-function code is used to set the communication protocol of a module.

Request

00	Address	1 Byte	1 ~ 247
01	Function code	1 Byte	0x46
02	Sub-function code	1 Byte	0x06
03	Reserved	1 Byte	0x00
04	Baud Rate	1 Byte	Baud rate code, see Section 1.9 for details.
05	Reserved	1 Byte	0x00
06	Data format	1 Byte	0x00: no parity, 1 stop bit 0x01: no parity, 2 stop bits 0x02: even parity, 1 stop bit 0x03: odd parity, 1 stop bit
07	Reserved	1 Byte	0x00
08	Mode	1 Byte	0x00: DCON protocol 0x01: Modbus RTU protocol 0x03: Modbus ASCII protocol
09~10	Reserved	2 Bytes	0x00 0x00

Response

00	Address	1 Byte	1 ~ 247
01	Function code	1 Byte	0x46
02	Sub-function code	1 Byte	0x06
03	Reserved	1 Byte	0x00
04	Baud Rate	1 Byte	0x00: OK, others: error
05	Reserved	1 Byte	0x00 0x00 0x00
06	Data format	1 Byte	0x00: OK, others: error
07	Reserved	1 Byte	0x00
08	Mode	1 Byte	0x00: OK, others: error
09~10	Reserved	2 Bytes	0x00 0x00

Note: The new baud rate and protocol will be effective after the next power-on reset.

Error Response

00	Address	1 Byte	1 ~ 247
01	Function code	1 Byte	0xC6
02	Exception code	1 Byte	Refer to the Modbus standard for more details.

3.7.5 Sub-function 32 (0x20) Read firmware version

This sub-function code is used to read the firmware version information of a module.

Request

00	Address	1 Byte	1 ~ 247
01	Function code	1 Byte	0x46
02	Sub-function code	1 Byte	0x20

Response

00	Address	1 Byte	1 ~ 247
01	Function code	1 Byte	0x46
02	Sub-function code	1 Byte	0x20
03	Major version	1 Byte	0x00~0xFF
04	Minor version	1 Byte	0x00~0xFF
05	Build version	1 Byte	0x00~0xFF

Error Response

00	Address	1 Byte	1 ~ 247
01	Function code	1 Byte	0xC6
02	Exception code	1 Byte	Refer to the Modbus standard for more details.

3.7.6 Sub-function 33 (0x21) Set digital input counter trigger edge

This sub-function code is used to set the digital input counter trigger edge value of a module.

Request

00	Address	1 Byte	1 ~ 247
01	Function code	1 Byte	0x46
02	Sub-function code	1 Byte	0x21
03	Edge setting value	1 Byte	*0x00~0x0F

*1 = rising edge, 0 = falling edge. For example 0x03 denotes that channels 0~1 are set as rising edge and channels 2~3 are set as falling edge.

Response

00	Address	1 Byte	1 ~ 247
01	Function code	1 Byte	0x46
02	Sub-function code	1 Byte	0x21
03	Edge setting value	1 Byte	0x00: OK others: error

Error Response

00	Address	1 Byte	1 ~ 247
01	Function code	1 Byte	0xC6
02	Exception code	1 Byte	Refer to the Modbus standard for more details.

3.7.7 Sub-function 34 (0x22) Read digital input counter trigger edge value

This sub-function code is used to read the digital input counter trigger edge value of a module.

Request

00	Address	1 Byte	1 ~ 247
01	Function code	1 Byte	0x46
02	Sub-function code	1 Byte	0x22

Response

00	Address	1 Byte	1 ~ 247
01	Function code	1 Byte	0x46
02	Sub-function code	1 Byte	0x22
03	Edge setting value	1 Byte	*0x00~0x0F

*1 = rising edge, 0 = falling edge. For example 0x03 denotes that channels 0~1 are set as rising edge and channels 2~3 are set as falling edge.

Error Response

00	Address	1 Byte	1 ~ 247
01	Function code	1 Byte	0xC6
02	Exception code	1 Byte	Refer to the Modbus standard for more details.

3.7.8 Sub-function 39 (0x27) Set the power-on value

This sub-function code is used to set the power-on value of a module.

Request

00	Address	1 Byte	1 ~ 247
01	Function code	1 Byte	0x46
02	Sub-function code	1 Byte	0x27
03	Power-on Value	1 Byte	*0x00~0xFF

*0x00~0x0F for tM-P4C4

0x00~0xFF for tM-C8

Response

00	Address	1 Byte	1 ~ 247
01	Function code	1 Byte	0x46
02	Sub-function code	1 Byte	0x28
03	Power-on value	1 Byte	0x00: OK, others: error

Error Response

00	Address	1 Byte	1 ~ 247
01	Function code	1 Byte	0xC6
02	Exception code	1 Byte	Refer to the Modbus standard for more details.

3.7.9 Sub-function 40 (0x28) Read the power-on value

This sub-function code is used to read the power-on value of a module.

Request

00	Address	1 Byte	1 ~ 247
01	Function code	1 Byte	0x46
02	Sub-function code	1 Byte	0x28

Response

00	Address	1 Byte	1 ~ 247
01	Function code	1 Byte	0x46
02	Sub-function code	1 Byte	0x28
03	Power-on value	1 Byte	*0x00~0xFF

*0x00~0x0F for tM-P4C4

0x00~0xFF for tM-C8

Error Response

00	Address	1 Byte	1 ~ 247
01	Function code	1 Byte	0xC6
02	Exception code	1 Byte	Refer to the Modbus standard for more details.

3.7.10 Sub-function 41 (0x29) Set DI/O active states

This sub-function code is used to set the DI/O active states of a module.

Request

00	Address	1 Byte	1 ~ 247
01	Function code	1 Byte	0x46
02	Sub-function code	1 Byte	0x29
03	DI/O active states	1 Byte	*0x00~0x03 Refer to the table below.

*0x00~0x03 for tM-P4C4
 0x00 and 0x02 for tM-C8
 0x00 and 0x01 for tM-P8

DI/O active states:

7	6	5	4	3	2	1	0
Reserved						OAS	IAS

Key	Description
OAS	DO active state 0: output value 1 for relay active output value 0 for relay inactive 1: output value 0 for relay active output value 1 for relay inactive
IAS	DI active state 0: input value 1 for non-signal or the low voltage; input value 0 for high voltage 1: input value 0 for non-signal or the low voltage; input value 1 for high voltage

Response

00	Address	1 Byte	1 ~ 247
01	Function code	1 Byte	0x46
02	Sub-function code	1 Byte	0x29
03	Power-on value	1 Byte	0x00: OK others: error

Error Response

00	Address	1 Byte	1 ~ 247
01	Function code	1 Byte	0xC6
02	Exception code	1 Byte	Refer to the Modbus standard for more details.

Note: After using the command, the DIO active states will immediately change and will simultaneously clear the DI counter and latch values.

3.7.11 Sub-function 42 (0x2A) Read DI/O active states

This sub-function code is used to read the DI/O active states of a module.

Request

00	Address	1 Byte	1 ~ 247
01	Function code	1 Byte	0x46
02	Sub-function code	1 Byte	0x2A

Response

00	Address	1 Byte	1 ~ 247
01	Function code	1 Byte	0x46
02	Sub-function code	1 Byte	0x2A
03	DI/O active status	1 Byte	*0x00~0x03

*0x00~0x03 for tM-P4C4

0x00 and 0x02 for tM-C8

0x00 and 0x01 for tM-P8

Error Response

00	Address	1 Byte	1 ~ 247
01	Function code	1 Byte	0xC6
02	Exception code	1 Byte	Refer to the Modbus standard for more details.

3.8 Modbus Address Mappings

Address	Description	Attribute																				
30001 ~ 30008	Counter value of digital input	R																				
40001 ~ 40008	Counter value of digital input	R																				
40481	Firmware version (low word)	R																				
40482	Firmware version (high word)	R																				
40483	Module name (low word)	R																				
40484	Module name (high word)	R																				
40485	Module address, valid range: 1 ~ 247	R/W																				
40486	Bits 5:0 Baud rate, 0x03 ~ 0x0A <table border="1" data-bbox="363 913 1034 1093"> <tbody> <tr> <td>Code</td> <td>0x03</td> <td>0x04</td> <td>0x05</td> <td>0x06</td> </tr> <tr> <td>Baud</td> <td>1200</td> <td>2400</td> <td>4800</td> <td>9600</td> </tr> <tr> <td>Code</td> <td>0x07</td> <td>0x08</td> <td>0x09</td> <td>0x0A</td> </tr> <tr> <td>Baud</td> <td>19200</td> <td>38400</td> <td>57600</td> <td>115200</td> </tr> </tbody> </table> Bits 7:6 00: no parity, 1 stop bit 01: no parity, 2 stop bits 10: even parity, 1 stop bit 11: odd parity, 1 stop bit	Code	0x03	0x04	0x05	0x06	Baud	1200	2400	4800	9600	Code	0x07	0x08	0x09	0x0A	Baud	19200	38400	57600	115200	R/W
Code	0x03	0x04	0x05	0x06																		
Baud	1200	2400	4800	9600																		
Code	0x07	0x08	0x09	0x0A																		
Baud	19200	38400	57600	115200																		
40488	Modbus response delay time in ms, valid range: 0 ~ 30	R/W																				
40489	Host watchdog timeout value, 0 ~ 255, in 0.1s	R/W																				
40492	Host watchdog timeout count, write 0 to clear	R/W																				
10033 ~ 10040	Digital input value of channel 0 ~ 7	R																				
10065 ~ 10072	High latched values of DI	R																				
10073 ~ 10080	High latched values of DO	R																				

Address	Description	Attribute
10097 ~ 10104	Low latched values of DI	R
10105 ~ 10112	Low latched values of DO	R
00001 ~ 00008	Digital output value of channel 0 ~ 7	R/W
00033 ~ 00040	Digital input value of channel 0 ~ 7	R
00065 ~ 00072	High latched values of DI	R
00073 ~ 00080	High latched values of DO	R
00097 ~ 00104	Low latched values of DI	R
00105 ~ 00112	Low latched values of DO	R
00129 ~ 00136	Safe value of digital output channel 0 ~ 7	R/W
00161 ~ 00168	Power on value of digital output channel 0 ~ 7	R/W
00193 ~ 00200	Counter update trigger edge of channel 0 ~ 7	R/W
00513 ~ 00520	Write 1 to clear counter value of channel 0 ~ 7	W
00257	Protocol, 0: DCON, 1: Modbus RTU	R/W
00258	0: Modbus RTU, 1: Modbus ASCII	R/W
00260	Modbus host watchdog mode 0: same as I-7000 1: can use AO and DO command to clear host watchdog timeout status	R/W
00261	1: enable, 0: disable host watchdog	R/W
00264	Write 1 to clear latched DIO	W
00265	DI active state, 0: normal, 1: inverse	R/W

Address	Description	Attribute
00266	DO active state, 0: normal, 1:inverse	R/W
00270	Host watch dog timeout status, write 1 to clear host watch dog timeout status	R/W
00273	Reset status, 1: first read after powered on, 0: not the first read after powered on	R

4. Troubleshooting

If you are having difficulty using the tM module, here are some suggestions that may help. If you cannot find the answers you need in these guides, contact ICP DAS Product Support. Contact information is located in Section 1.12.

4.1 Communicating with the module

If you attempt to communicate with the module and receive no response, first check the following:

- Ensure that the supplied power is within the range of +10 to +30 V DC. If the supplied power is OK, then the power LED should be on.
- When the module receives a command, the power LED is set to “off”. The power LED is shown as “on” after the module responds. This method can be used to check whether the module has received a command sent from the host.
- If possible, use another device to check whether the host can communicate with the device through the same RS-485 network.
- If the host is a PC installed with a Windows operating system, then execute the DCON Utility to determine whether the module can be found. The DCON Utility can be downloaded from the ICP DAS website <http://www.icpdas.com>. The DCON Utility documentation can be found in the **”Getting Started For I-7000 Series Modules”** manual.
- Set the module to “INIT mode” and communicate with the module using the following settings: address 00, Baud Rate 9600bps and no checksum. See Section A.1 for details.

A. Appendix

A.1 INIT Mode

Each tM module has a built-in EEPROM to store configuration information such as module address, type code, Baud Rate, etc. Occasionally, the configuration of a module may be forgotten and there are no visual indications of the configuration of the module. It is difficult to communicate with the module when the configuration of the module is unknown. To help avoid this problem, the tM series has a special mode called “**INIT mode**”. When the module is powered on in “**INIT mode**” the configuration of the module is reset as follows, allowing it to be operated as normal.

1. Address: 00
2. Baud Rate: 9600 bps
3. No checksum
4. Protocol: DCON

The configuration information stored in the EEPROM is not changed and can be read by sending the \$002(CR) command at 9600bps.

There are commands that require the module to be in INIT mode. They are:

1. %AANNTTCFF when changing the Baud Rate and checksum settings. See Section 2.1 for details.
2. \$AAPN, see Section 2.20 for details.

The tM modules have the INIT switch located on the right side of the module to allow easier access to the INIT mode. For these modules, INIT mode is accessed by sliding the INIT switch to the Init position as shown below.



A.2 Dual Watchdog Operation

Dual Watchdog = Module Watchdog + Host Watchdog

The Module Watchdog is a hardware reset circuit that monitors the operating status of the module. While working in harsh or noisy environments, the module may be shut down by external signals. The circuit allows the module to work continuously without disruption.

The Host Watchdog is a software function that monitors the operating status of the host. Its purpose is to prevent problems due to network/communication errors or host malfunctions. When a host watchdog timeout occurs, the module will reset all outputs to a safe state in order to prevent any erroneous operations of the controlled target.

The tM series modules include an internal Dual Watchdog, making the control system more reliable and stable.

For more information regarding the Dual Watchdog, please refer to Chapter 5 of the “**Getting Started For I-7000 Series Modules**” manual that can be downloaded from the ICP DAS website <http://www.icpdas.com>.

A.3 Frame Ground

Electronic circuits are constantly vulnerable to Electro-Static Discharge (ESD), which become worse in a continental climate area. The tM modules feature a new design for the frame ground, which provides a path for bypassing ESD, allowing enhanced static protection (ESD) capability and ensures that the module is more reliable.

Connect the frame ground terminal to a wire/DIN rail and connect the wire/DIN rail to the earth ground will provide a better protection for the module.

A.4 Reset Status

The reset status of a module is set when the module is powered-on or when the module is reset by the module watchdog. It is cleared after the responding of the first \$AA5 command. This can be used to check whether the module had been reset. When the \$AA5 command responds that the reset status is cleared, that means the module has not been reset since the last \$AA5 command was sent. When the \$AA5 command responds that the reset status is set and it is not the first time \$AA5 command is sent, it means the module has been reset and the digital output value had been changed to the power-on value.

A.5 Safe Value and Power-on Value of Digital Output

Besides setting by the set digital output commands, the digital outputs can be set under two other conditions.

When the host watchdog is enabled and a host watchdog timeout occurs, the “**safe value**” is loaded into the digital output ports. The set digital output commands have no effect on the digital output ports until the host watchdog timeout status is cleared. The host watchdog timeout status is saved in the EEPROM. The status is not changed even after power-on reset. It can be cleared only by the reset host watchdog timeout status command ~AA1. See Section A.2 for host watchdog details.

When the module is powered on and the host watchdog timeout status is cleared, the “**power-on value**” is loaded into the digital output ports. If the host watchdog timeout status is not cleared on power-on, then the safe value is loaded into the digital output ports.

Both the safe value and power-on value are set by the ~AA5V command. Refer to Section 2.30 for details.

A.6 Latched Digital Input

The tM modules provide commands to read the latched high digital input and latched low digital input status. Following is an example to show the usefulness of the latched digital input. When we want to read the key stroke of a key switch connected to the digital input channel of a module, the input signal of the key stroke is a pulse signal as shown in the following figure.

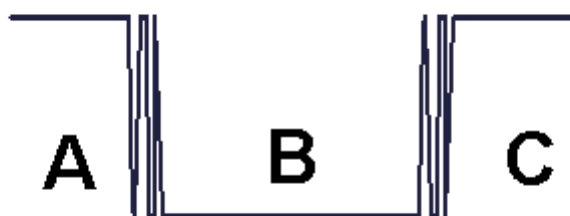

If we just use the read digital input status command to read the signal and we cannot send the command during the B period due to some reasons, then we will lose the key stroke information. However, with the read latched digital input command, we can still get the key stroke information even we are not able to send command in B period. For details of the read latched digital input command, please refer to Sections 2.17 and 3.1.

A.7 DN Module

The DN modules are the I/O extension of the tM modules. They can drive more power and heavy load. User may use tM modules to control the DN modules to drive the loads.

A.7.1 DN-SSR4

Output Channel	4 solid state relay contact
Output Specifications	
Type	Zero-cross AC solid-state relay output
Rated Load Voltage	200 to 240 VAC
Rated Load Current	4 A _{rms}
Surge Current	50 A
Max. Off-State Leakage Current	5.0 mA
Operate Time	1/2 cycle of voltage sine wave + 1ms
Input Impedance	1.5K Ohms
Power Input	+24 VDC
DIN-Rail Mounted	

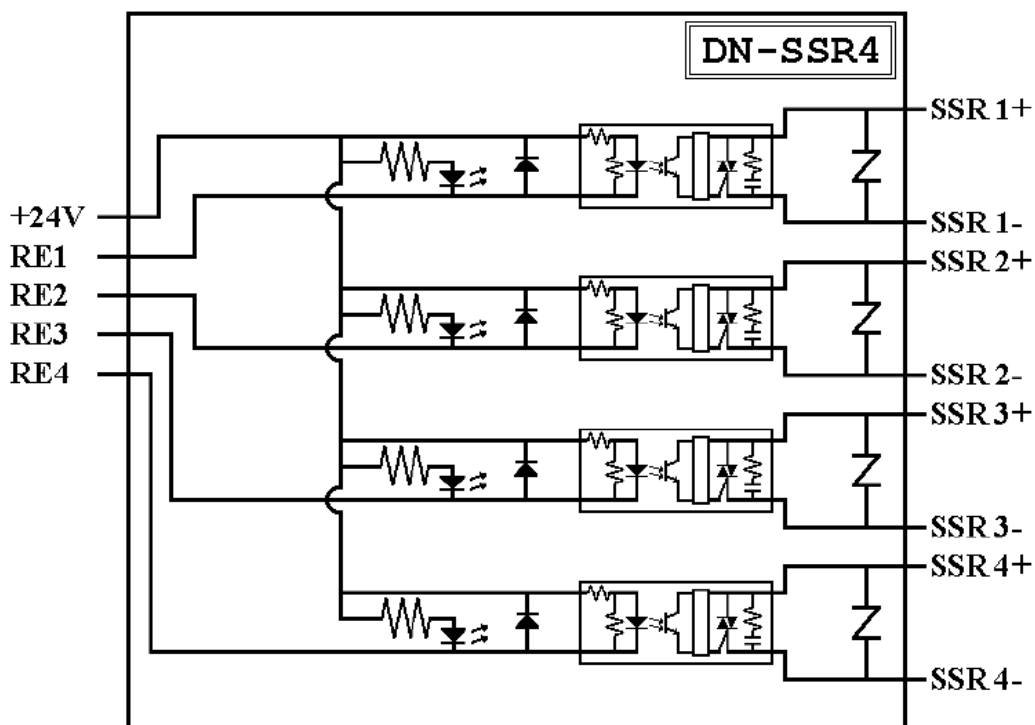

A.7.2 DN-PR4

Output Channel	4 relay contact
Output Specifications	
Type	1 Form C relay contact
Nominal Load	5A@250VAC, 5A@30VDC
Max. Switching Power	1250 VA
Max. Switching Voltage	250 VAC, 150 VDC
Max. Switching Current	5 A
Mechanical Life	10 x 10 ⁶ operations min.
Electric Life	100 x 10 ³ operations min.
Operate/Release Time	Max. 10 ms / 5 ms
Dielectric Strength	2000 VAC 1 minute
Nominal Coil Power	360 mW
Power Input	+24 VDC
DIN-Rail Mounted	

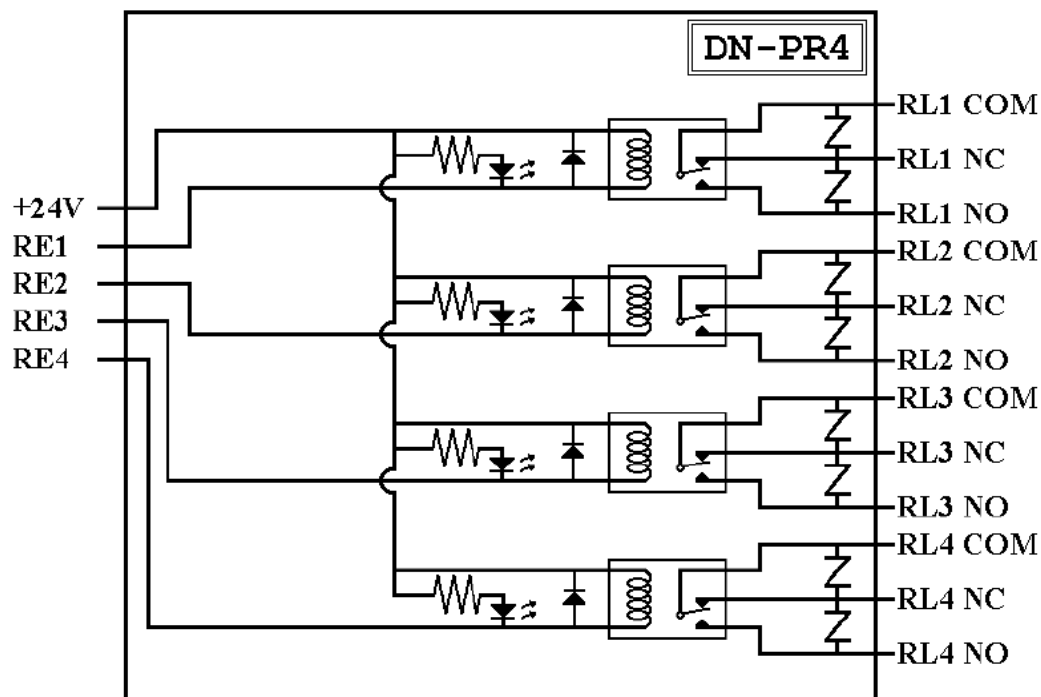

A.7.3 RM-104, RM-108, and RM-116

Output Channel	4/8/16 relay contact
Output Specifications	
Type	1 Form C relay contact
Rated Load	16A@250VAC
Max. Switching Voltage	400 VAC
Max. Peak Current	30 A
Contact Material	AgCdO
Min. Life	100,000 operations
Dimensions	
RM-104	78 mm x 77 mm
RM-108	135 mm x 77 mm
RM-116	270 mm x 77 mm
Power Input	+24 VDC
DIN-Rail Mounted	

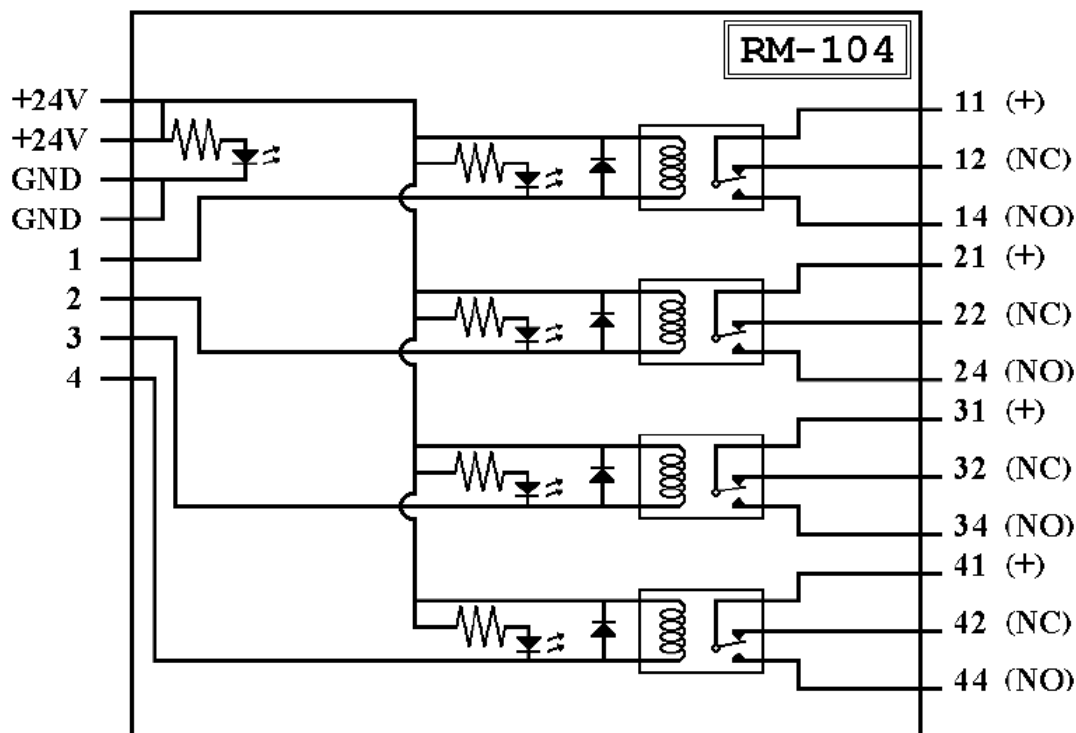

A.7.4 RM-204, RM-208, RM-216

Output Channel	4/8/16 relay contact
Output Specifications	
Type	2 Form C relay contact
Rated Load	5A@250VAC
Max. Switching Voltage	400 VAC
Max. Peak Current	10 A
Contact Material	AgNi
Min. Life	100,000 operations
Dimensions	
RM-204	78 mm x 77 mm
RM-208	135 mm x 77 mm
RM-216	270 mm x 77 mm
Power Input	+24 VDC
DIN-Rail Mounted	

